

SINGLE PHASE WIRING FOR ASCO® SERIES G386 NON-AUTOMATIC TRANSFER SWITCHES RATED 1600-3000 AMPERES WITH GROUP I CONTROLS

FIELD CONNECTIONS

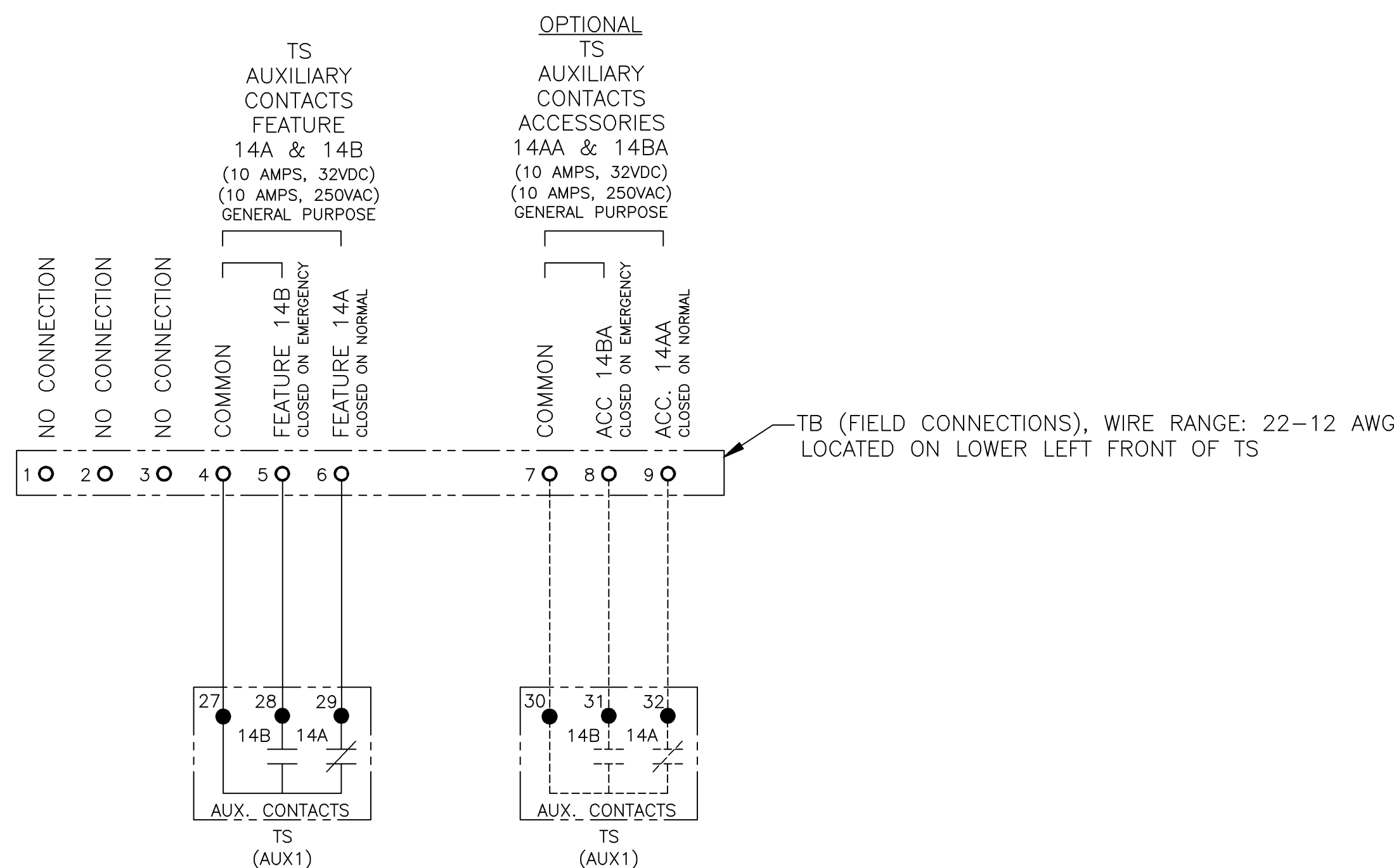

STANDARD FACTORY SETTINGS FOR CONTROL PANEL

1. FACTORY SETTINGS FOR DIP SWITCH S1, S2 & S3

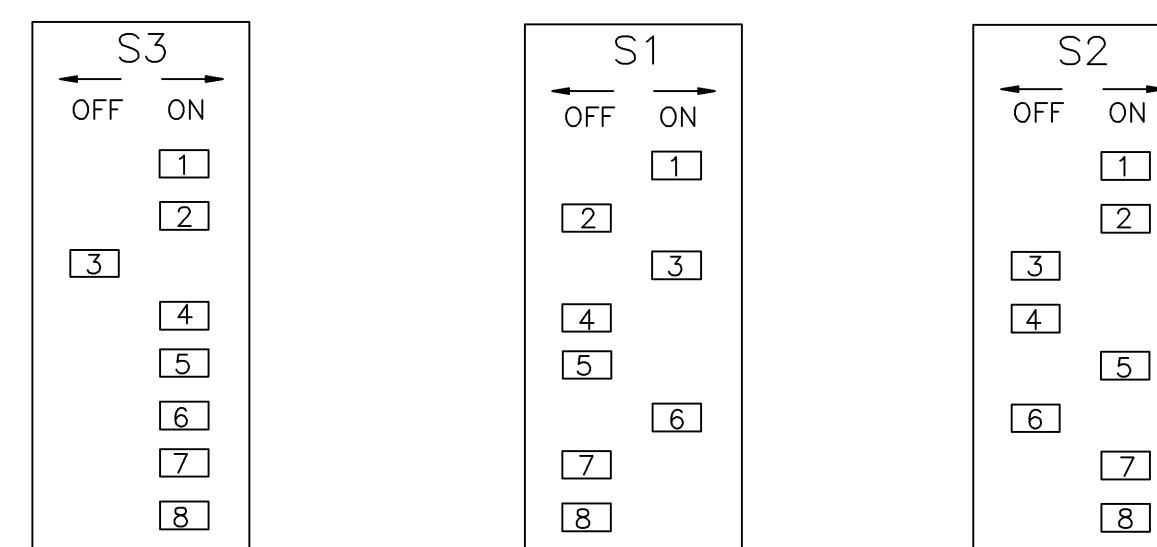

- P1 (TIMER E/N) SET UP FOR FULL CCW.
- P2 (TIMER N/E) SET UP FOR FULL CCW.
- NORMAL SOURCE VOLTAGE (PU/N) PICKUP FACTORY SETTING IS 90% (S1-ACTUATOR 3 ON). SETTING S1-ACTUATOR 3 OFF IS FOR 95% NORMAL SOURCE VOLTAGE PICKUP.
- EMERGENCY SOURCE VOLTAGE PICKUP FACTORY SETTING 90% (NON ADJUSTABLE). EMERGENCY SOURCE VOLTAGE DROPOUT FACTORY SETTING 75% (NON ADJUSTABLE). EMERGENCY SOURCE FREQUENCY PICKUP FACTORY SETTING 95% (NON ADJUSTABLE).

! WARNING:
ANY CHANGE IN THESE SETTINGS MAY AFFECT THE NORMAL OPERATION OF THE TRANSFER SWITCH.

GENERAL NOTES

- SWITCH SHOWN DE-ENERGIZED AND CONNECTED TO THE NORMAL SOURCE.
- DEVICE SYMBOLS AND DESIGNATIONS ARE IN ACCORDANCE WITH NEMA PUBLICATION ICS 1-1983, PART 1-101A.
- ALL WIRING IS #16 AWG, TINNED, STRANDED COPPER UNLESS OTHERWISE INDICATED.
- ON TERMINAL BLOCKS INDICATES AVAILABLE FIELD CONNECTION POINT.
- ON TERMINAL BLOCKS INDICATES FACTORY CONNECTION POINT.
- CONTROL AND ACCESSORY WIRING IS ROUTED IN ACCORDANCE WITH ASCO ASSEMBLY PROCEDURE GS451261.
- AN OPERATOR'S MANUAL IS FURNISHED WITH EACH TRANSFER SWITCH. REFER TO THIS PUBLICATION PRIOR TO INSTALLATION AND OPERATION OF THE UNIT.
- GROUND STRAP ON CONTROL PANEL IS AFFIXED TO CHASSIS (ENCLOSURE) AT LOWER LEFT CONTROL PANEL MOUNTING STUD.

FEATURES

- SELECTOR SWITCH (SS) FOR MANUAL TRANSFER TO NORMAL AND EMERGENCY. THREE POSITION, MOMENTARY, SPRING RETURN TO CENTER SELECTOR SWITCH.
- FEATURES 14A & 14B - TRANSFER SWITCH AUXILIARY POSITION INDICATING CONTACTS. ONE (1) FORM C CONTACT TO INDICATE CONNECTION OF THE TRANSFER SWITCH TO NORMAL (14A) AND ONE (1) FOR EMERGENCY (14B). CONTACT CONNECTED TO THE FIELD CONNECTIONS TERMINAL BLOCK (TB). CONTACTS RATED 10 AMPS, 32 VDC, 250 VAC.
- SIGNAL LIGHT PL1, (GREEN LED), INDICATES WHEN TRANSFER SWITCH IS CONNECTED TO NORMAL SOURCE. (STD. FEAT. 9A)
- SIGNAL LIGHT PL2, (RED LED), INDICATES WHEN TRANSFER SWITCH IS CONNECTED TO EMERGENCY SOURCE. (STD. FEAT. 9B)
- ONE SET OF FORM C CONTACTS (1 N/O & 1 N/C) THAT CHANGE POSITION ON EXPIRATION OF THE NORMAL SOURCE OUTAGE DELAY AND RESET ON EXPIRATION OF THE UNLOADED RUNNING (ENGINE COOL DOWN) DELAY. OUTPUT CONTACTS (NR) ARE RATED 6 AMPS RESISTIVE AT 28V DC OR 120V AC MAXIMUM.

OPTIONAL ACCESSORIES

- ACC. 6Q- KEY OPERATED TRANSFER CONTROL SWITCH. FOR TRANSFERRING TO NORMAL OR EMERGENCY. THREE POSITION MOMENTARY SPRING RETURN TO CENTER. KEY REMOVABLE IN CENTER POSITION.
- ACC. 9C- SIGNAL LIGHT (PL3 GREEN LED) INDICATES NORMAL SOURCE AVAILABLE.
- ACC. 9D- SIGNAL LIGHT (PL4 RED LED) INDICATES EMERGENCY SOURCE AVAILABLE.
- ACC. 14AA (2) AUXILIARY CONTACT CLOSED ON NORMAL.
- ACC. 14BA (2) AUXILIARY CONTACT CLOSED ON EMERGENCY.
- ACC. 27 - INPHASE TRANSFER CONTROL LOGIC TO INITIATE AN INPHASE TRANSFER OF LOADS BETWEEN LIVE SOURCES. USED TO PREVENT NUISANCE TRIPPING OF CIRCUIT BREAKERS AND POSSIBLE DAMAGE TO MECHANICAL LOADS CAUSED BY OUT OF PHASE TRANSFER. ACTIVATED BY SETTING A DIP SWITCH ON THE CONTROL PANEL. (FACTORY SET AS DISABLED). (REFER TO OPERATOR'S MANUAL FURNISHED WITH EACH TRANSFER SWITCH REGARDING CONTROL PANEL SETTINGS).
- ACC. 31 - ONE SET OF FORM C CONTACTS (1 N/O & 1 N/C) THAT CHANGE POSITION ON ACTIVATION OF A SELECTABLE TIME DELAY BEFORE TRANSFER (LD TDBT) AND RESET EITHER IMMEDIATELY FOLLOWING TRANSFER OR FOR THE SAME DELAYS SET FOR PRE-SIGNAL BEFORE TRANSFER. SELECTABLE AS 0, 3, 10 OR 20 SECONDS. FACTORY SET AT 0. (REFER TO THE OPERATOR'S MANUAL FURNISHED WITH EACH TRANSFER SWITCH REGARDING CONTROL PANEL SETTINGS). OUTPUT CONTACTS (OP) ARE RATED 5 AMPS RESISTIVE AT 28V DC OR 120V AC MAXIMUM.
- ACC. 37B- EXTENSION HARNESS FOR UNITS SHIPPED OPEN TO ACCOMMODATE CUSTOMER MOUNTING OF CONTROLS AND SWITCH. EXTENSION IS 72IN (1828mm) LONG.
- ACC. 43M- PROVISIONS FOR CUSTOMER SUPPLIED 3-POSITION SELECTOR SWITCH. POSITION 1- LOCAL CONTROL ENABLE POSITION 2- REMOTE CONTROL TRANSFER TO NORMAL POSITION 3- REMOTE CONTROL TRANSFER TO EMERGENCY
- ACC. 72A- SERIAL COMMUNICATIONS INTERFACE. RS-485 SERIAL INTERFACE TO CONTROL PANEL. FOR REMOTE MONITORING AND CONTROL FROM ASCO COMMUNICATIONS BASED PRODUCTS.

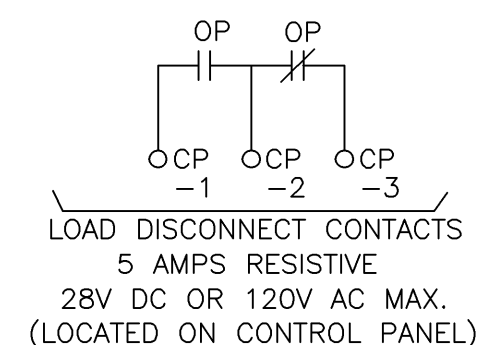

ACC. 72A SERIAL COMMUNICATIONS OPTION COMMUNICATING WITH GROUP 1 CONTROL PANEL (CP)

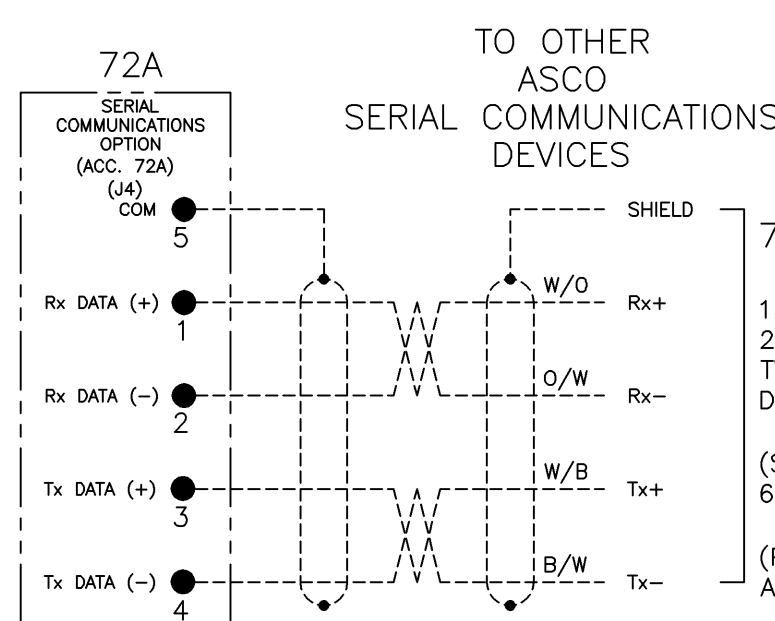

- 72A NOTES:**
- EARTH GROUND SHIELD AT HOST DEVICE ONLY.
 - FIELD WIRING: USE UL LISTED, STRANDED, TWISTED PAIRS. OVERALL FOIL SHIELD WITH STRANDED DRAIN WIRE SUITABLE FOR RS-422 EQUIVALENT TO: (STANDARD 80°C) BELDEN 9842 OR 9829 OR ALPHA 6202C OR 6222C (PLENUM RATED) BELDEN 89729 OR 82729 OR ALPHA 58902

BASE CATALOG NUMBER				CATALOG NUMBER SUFFIXES				EXPLANATION OF CATALOG NUMBER CODES												
TS FRAME	CATALOG TYPE	NEUTRAL TYPE	PHASE POLES	AMPS	VOLT CODE	CONTROLLER	OPTIONAL ACCESSORY	ENCLOSURE CODE	NEUTRAL TYPE		VOLTAGE CODES		ENCLOSURE CODES							
									CODE	DESCRIPTION	CODE	NOMINAL VOLTAGE	CODE	TYPE	DESCRIPTION					
G	386	A B C	2	1600 2000 2600 3000	H J K L M N P Q R	1	X	C F G	BLANK A B C	NONE SOLID SWITCHING OVERLAPPING	C D E F	208 220 230 240	BLANK C	1	OPEN TYPE (NO ENCLOSURE) GENERAL PURPOSE, INDOOR					
											H J K L M N P Q R	380 400 415 440 460 480 550 575 600	L	12	INDOOR, INDUSTRIAL ENVIRONMENTS, OILTIGHT & DUSTTIGHT					
		BLANK FOR NONE													BLANK FOR OPEN TYPE					

CATALOG NUMBER _____

ASCO CERTIFIED TO S.O. _____

BY _____

DATE _____

FORM REV D

PROJECT NAME: _____

WIRING _____ DIAGRAM _____

SERIES G386 TS,1PH, 1600-3000 AMPS

"G" FRAME, GROUP 1 CONTROLS

DRAWN BY	BWM	DATE	1/03	MANUFACTURING TOLERANCES TO BE IN ACCORDANCE WITH ASCO PROCEDURE MP-1-003. FOR PLASTIC PARTS SEE MP-1-055	ASSEM. REF. NO.		COMPUTER GENERATED DRAWING
CHECKED	BK	DATE	1/03	PROPERTY OF ASCO POWER TECHNOLOGIES. USE PERMITTED FOR OUR WORK ONLY. ALL RIGHTS OF DESIGN OR INVENTION ARE RESERVED.			SCALE 1:1 SIZE DS
PROJECT APPROVAL							DWG. NO. 733604
FINAL APPROVAL	WK	DATE	1/03				DRAWING D ECN NO. 212659 SHEET 10F.4

D	212659	WK	BK	03/29/07
C	167230	DJB	WK	06/04/04
B	167059	SDH	SDH	05/25/04
A	166172	AJM	BK	02/17/04
	162494	BWM	WK	1/03

NORMAL SOURCE CIRCUITS

NORMAL

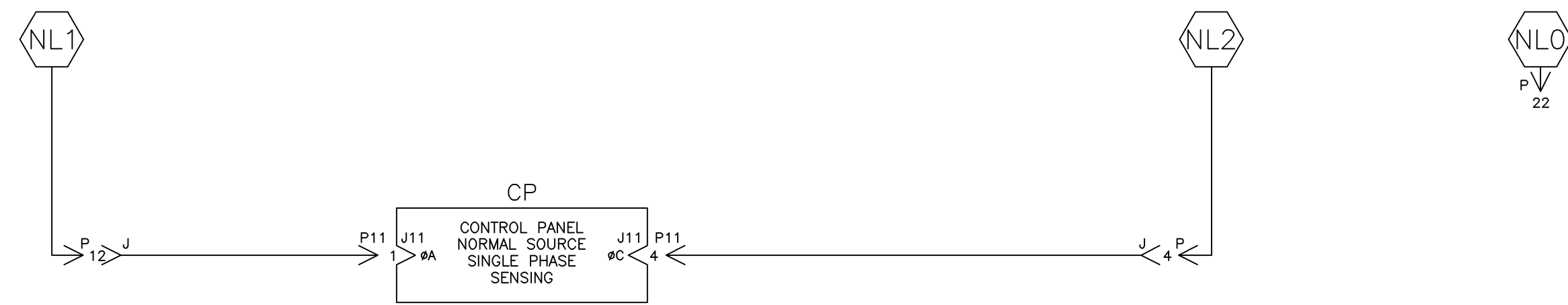

EMERGENCY SOURCE CIRCUITS

EMERGENCY

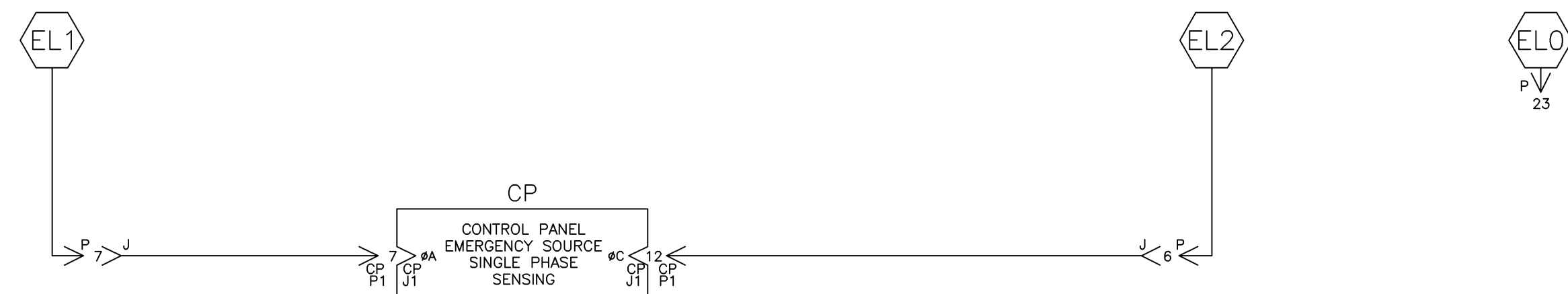

LOAD TERMINAL CIRCUITS

LOAD



CONTROL SIGNALS & INDICATION

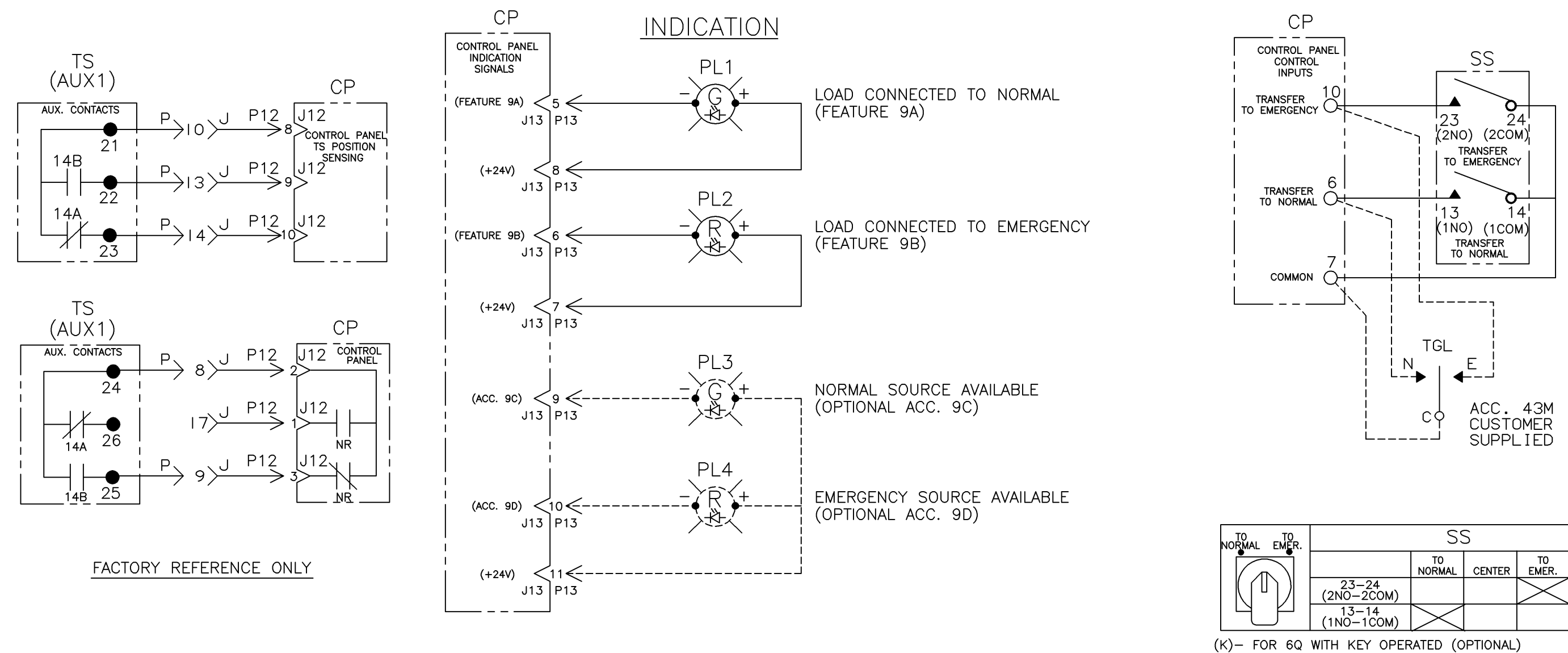

HARNESS LOCATOR BOX CHECKED IF HARNESS IS MODIFIED

WIRE No.	HARNESS 605454 (P,P1,P2,J3) MAIN TS	CLR	AWG
1	P-2,TS-1		16
2	P-3,P1-14		
3	P-4,TS-3		
4	P-5,TS-9		
5	P-6,TS-7		
4	P-7,TS-5		
6	P-8,TS(AUX1)-24		
6	TS(AUX1)-24,J3-1		
7	P-9,TS(AUX1)-25		
7	TS(AUX1)-25,J3-2		
8	P-10,TS(AUX1)-21		
9	P-11,TS-2		
10	P-12,TS-1		
11	P-13,TS(AUX1)-22		
12	P-14,TS(AUX1)-23		
13	P-16,P1-16		
14	P-17,J3-3		
15	P-18,TS-6		
16	P-19,TS-9		
17	P-20,TS-10		
18	P-21,TS-11		
19	P-22,TS-4		
20	P-23,TS-8		
21	P-24,TS-12		
22	P1-5,TS(MUS)-17		
22	TS(MUS)-17,TS(MUS)-15		
23	P1-6,TS(MUS)-19		
23	TS(MUS)-19,TS(MUS)-13		
24	P1-9,P2-4		
25	P1-10,P2-1		
26	P1-11,P2-2		
27	P1-12,P2-3		
28	P1-13,TS(MUS)-16		
28	TS(MUS)-16,TS(MUS)-14		
29	P1-15,TS(MUS)-20		
29	TS(MUS)-20,TS(MUS)-18		
1	P1-17,TS-1		
4	P1-18,TS-5		
3	P1-19,TS-3		
5	P1-20,TS-7		
30	P1-21,P1-23		
DEAD END WIRES			
9	P-11,TS-2		
15	P-18,TS-6		
17	P-20,TS-10		
REMOVE WIRES			
6	TS(AUX1)-24,J3-1		
7	TS(AUX1)-25,J3-2		
14	P-17,J3-3		

ADDITIONAL WIRE CONNECTIONS

WIRE No.	CLR	AWG
31	TS(AUX1)-27,TB-4	16
32	TS(AUX1)-28,TB-5	
33	TS(AUX1)-29,TB-6	

OPTIONAL ACCESSORIES

WIRE No.	OPTIONAL ACC. 14AA & 14BA	CLR	AWG
39	TS(AUX1)-30,TB-7		16
40	TS(AUX1)-31,TB-8		
41	TS(AUX1)-32,TB-9		

HARNESS LOCATOR BOX CHECKED IF HARNESS IS MODIFIED

WIRE No.	HARNESS 483763 (J, P11, P12) TS-CP HARNESS	CLR	AWG
170	J-1,P11-8		16
171	J-2,P11-15		
172	J-3,P11-2		
173	J-4,P11-4		
174	J-5,P11-17		
175	J-6,P11-12		
176	J-7,P11-7		
177	J-8,P12-2		
178	J-9,P12-3		
179	J-10,P12-8		
180	J-11,P11-10		
181	J-12,P11-1		
182	J-13,P12-9		
183	J-14,P12-10		
184	J-15,P11-5		
185	J-16,P11-13		
186	J-17,P12-1		

HARNESS LOCATOR BOX CHECKED IF HARNESS IS MODIFIED

WIRE No.	HARNESS 619510-037 (P3) DOOR CONTROLS & INDICATORS	CLR	AWG
140	P13-5,PL1(-)		22
141	P13-8,PL1(+)		
142	P13-6,PL2(-)		
143	P13-7,PL2(+)		
144	P13-9,PL3(-) * SEE NOTE		
145	P13-10,PL4(-) *		
146	P13-11,PL3(+)		
146	PL3(+),PL4(+)		
147	CP-6,SS-13		
148	CP-10,SS-23		
149	CP-7,SS-14		
149	SS-14,SS-24		

* NOTE: CONNECTIONS ARE OPTIONAL FOR ACC. 9C, 9D.

OPTIONAL ACC. 6Q

WIRE No.	HARNESS 619510-037 WITH 6Q KEY OPTION REMOVE WIRES	CLR	AWG
147	CP-6,SS-13		
148	CP-10,SS-23		
149	CP-7,SS-14		
149	SS-14,SS-24		
ADD WIRES			
147	CP-6,SS-1NO		
148	CP-10,SS-2NO		
149	CP-7,SS-1COM		
149	SS-1COM,SS-2COM		

D	212659	WK	BK	03/29/07
C	167230	DJB	WK	06/04/04
B	167059	SDH	SDH	05/25/04
A	166172	AJM	BK	02/17/04
-	162494	BWM	WK	1/03

PROJECT NAME: **WIRING DIAGRAM**

SERIES G386 TS,1PH, 1600-3000 AMPS

"G" FRAME, GROUP 1 CONTROLS

ASCO POWER TECHNOLOGIES, L.P. FLOHAM PARK, NEW JERSEY 07932 U.S.A.

733604

SCALE: 1:1 SIZE: DS

COMPUTER GENERATED DRAWING

DATE: 1/03

BY: BWM

CHECKED: BK

PROJECT APPROVAL: WK

FINAL APPROVAL: WK

REV. TO SHEET: ECN NO. 212659

BY: APP. DATE

ASSEM. REF. NO.

PROPERTY OF ASCO POWER TECHNOLOGIES. USE PERMITTED FOR OUR WORK ONLY. ALL RIGHTS OF DESIGN OR INVENTION ARE RESERVED.

SCALE: 1:1 SIZE: DS

DWG. NO. 733604

DRAWING D ECN NO. 212659 SHEET 3 OF 4

