



Gas Engine Generator Set

G3508

1200 rpm

60 Hz

210-395 kW

Continuous Power

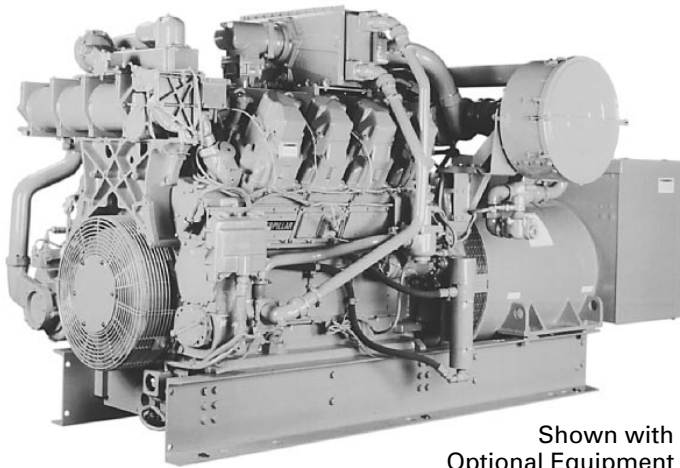

Shown with
Optional Equipment

CATERPILLAR® ENGINE SPECIFICATIONS

V-8, 4-Stroke-Cycle Spark-Ignited

Bore — in (mm) 6.7 (170)

Stroke — in (mm) 7.5 (190)

Displacement — cu in (L) 2105 (33.7)

Aspiration Turbocharged-Aftercooled

Compression ratio 11:1, 9:1

FEATURES

■ CATERPILLAR® FACTORY PACKAGE

Factory designed, assembled, and tested. Supported by Caterpillar parts and labor warranty through your local Caterpillar dealer.

■ DIESEL STRENGTH BUILT IN

Blocks, crankshafts, liners, and connecting rods are common with higher loaded Cat® diesel engines. Robust design provides prolonged life at lower gas engine loads.

■ ELECTRONIC IGNITION SYSTEM WITH DETONATION SENSITIVE TIMING

The Caterpillar Electronic Ignition System (EIS) provides optimized spark timing for all operating conditions. Timing is automatically controlled to maintain continuous detonation protection.

■ LOW EXHAUST EMISSIONS

2.0 gram/bhp-hr NO_x. Lower emissions are achievable for selected applications; consult your Caterpillar dealer.

■ FUEL FLEXIBILITY

Capability to burn a wide range of gaseous fuels, including landfill gas, digester gas, coal seam gas, and propane.

■ GALLERY COOLED PISTONS

Oil passageways provide cooler piston temperatures which prevent carbon build-up and increase detonation margin.

■ COOLING WATER TEMPERATURE

Choice of cooling water temperature between 99° C and 127° C to match heat recovery requirements.

CATERPILLAR® SR4 GENERATOR

Type Static regulator, brushless excited
Construction Single bearing, close coupled
Three phase Wye connected
Insulation Class F
Enclosure Drip proof
Alignment Caterpillar pilot shaft
Overspeed capability 130%
Waveform Less than 5% deviation
Voltage regulator 3-phase sensing with
Volts-per-Hertz

Voltage regulation Less than ± 1%
Voltage gain Adjustable to compensate for
engine speed droop and line loss
TIF Less than 50
THF Less than 3%



STANDARD EQUIPMENT

Air cleaners with
service indicator
Breather, crankcase
Cooler, lubricating oil
Filters, lubricating oil, RH
Flywheel housing,
SAE No. 00
Governor (Woodward),
magneto engine: 2301
EIS engine: 2301A
Ignition system,
Altronic III or
Caterpillar EIS
Instrument panel,
RH or LH
exhaust temp.
intake manifold
pressure
intake manifold
temp.
oil pressure
oil pressure
differential
service meter
water temp.

Lifting eyes
Manifold, exhaust,
watercooled
Paint,
Caterpillar yellow
Protection devices
Pumps
gear driven
aftercooler water
lubricating oil
jacket water
Rails, mounting, 10 inch
Regulator,
gas pressure
SAE standard rotation
Thermostats
and housing
Torsional vibration
damper

OPTIONAL EQUIPMENT

Cooling systems,
high temperature
Custom generator
voltages
Exhaust fittings
Generator mounted
control panel
Load share governor
Low BTU arrangements
Low pressure gas fuel
system (2 psi)
Muffler
Power takeoffs
Prelube pump
Starting systems
Tachometer

TECHNICAL DATA

G3508 Gas Engine Generator Set–1200 rpm		90 LE	90 TA	NA
Electrical Output @ 0.8 PF without Fan	kW	395	375	210
Voltage		480	480	480
Compression Ratio		11:1	9:1	9:1
Minimum Gas Pressure Required	psi	30	25	1
Shipping Weight	lb	16 800	16 800	16 500
Gen Set Length	in	140.9	140.9	139.5
Gen Set Width	in	68.2	68.2	67.2
NO _x	g/bhp-hr	2.0	20.8	13.1
CO	g/bhp-hr	1.6	0.8	13.7
HC (total)	g/bhp-hr	2.7	1.7	3.0
HC (non-methane)	g/bhp-hr	0.4	0.3	0.5
Fuel Consumption (100% load)	Btu/hp-hr	7188	7464	7824
Fuel Consumption (75% load)	Btu/hp-hr	7379	7888	7951
Air Inlet Flow Rate	scfm	1129	805	453
Exhaust Gas Flow Rate @ Stack F	cfm	2779	2377	1165
Heat Rejection to Jacket Water (total)	Btu/min	21 155	23 430	13 705
Heat Rejection to Exhaust (to 350° F)	Btu/min	8815	10 009	7450
Heat Rejection to Aftercooler	Btu/min	3981	2730	–
Heat Rejection to Atmosphere from Engine	Btu/min	4834	3412	3128
Exhaust Gas Stack Temperature	Deg. F	733	943	1125

LE refers to low emission engine configuration.

TA refers to standard engine configuration.

90 refers to aftercooler water inlet temperature in °F.

130 refers to aftercooler water inlet temperature in °F.

All data is based on standard conditions.

These ratings do not allow for overload capability.

TOP VIEW

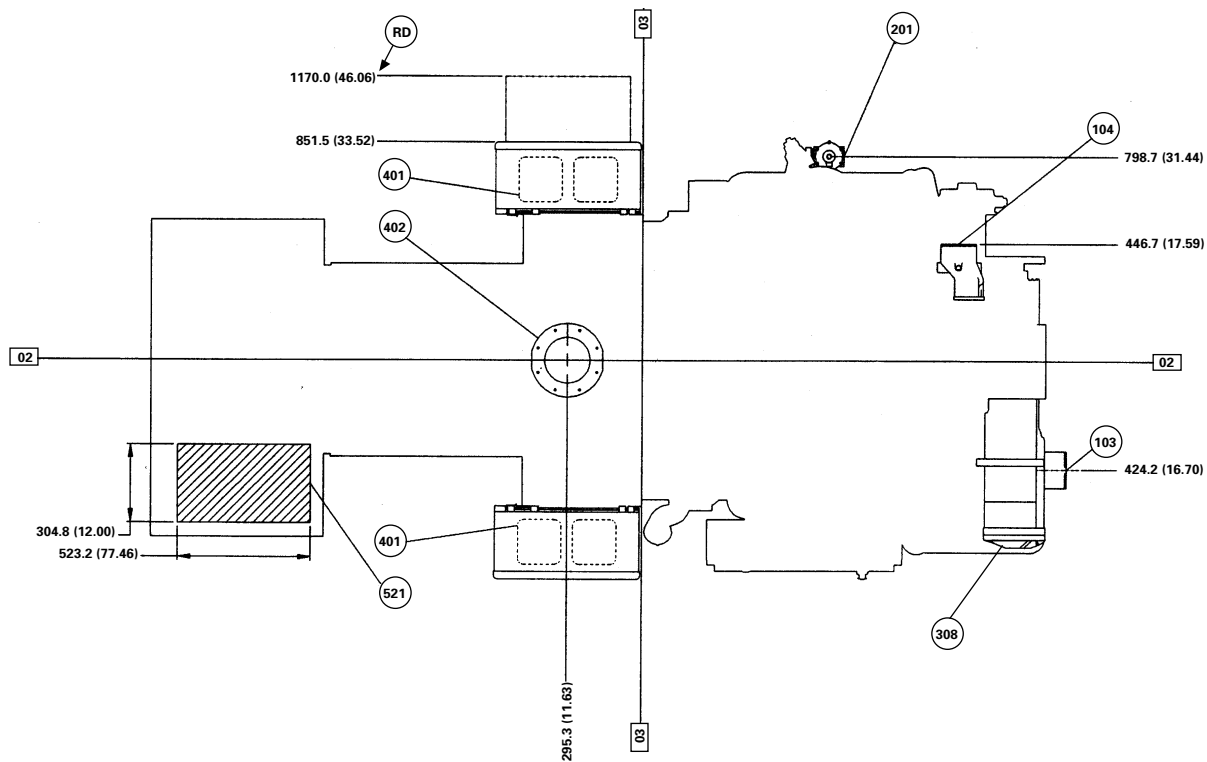

- | | | |
|---------------------------------------|-----------------------|-----------------------------|
| 02 Centerline of Engine | 201 Fuel Inlet | 521 Conduit Entrance |
| 03 Rear Face of Cylinder Block | 308 Oil Filter | RD Removal Distance |
| 103 Water Inlet | 401 Air Inlet | |
| 104 Water Outlet | 402 Exhaust | |

See general dimension drawing 120-6597 for additional Electronic Ignition System (EIS) engine detail and NA information.

For magneto ignition system engines see general dimension drawing 4P-5599.

Note: General configuration not to be used for installation.

CONDITIONS AND DEFINITIONS

Ratings are based on SAE J1349 standard conditions of 29.61 in Hg (100 kPa) and 77° F (25° C). These ratings also apply at ISO3046/1, DIN6271, and BS5514 standard conditions of 29.61 in Hg (100 kPa) and 81° F (27° C); and API 7B-11C standard conditions of 29.38 in Hg (99 kPa) and 85° F (29° C) also apply.

Ratings are based on dry natural gas having a low heat value of 905 btu/ft³ (35.22 MJ/m³). Variations in altitude, temperature and gas composition from standard conditions may require a reduction in engine horsepower.

Turbocharged-aftercooled ratings apply to 5000 ft (1525 m) and 77° F (25° C). **Naturally aspirated** engines apply to 500 ft (150 m) and 85° F (29° C). For applications which exceed these limits consult your Caterpillar dealer.

Continuous – Output available without varying load for an unlimited time. Continuous power in accordance with ISO8528, ISO3046/1, AS2789, DIN6271, and BS5514.

Additional ratings may be available for specific customer requirements. Consult your Caterpillar representative for details.