



GeneratorJoe

4016 Quartz Drive
Santa Rosa, CA 95405
Phone: 707 539-9003
Fax: 707 539-5212
Email: sales@generatorjoe.NET
Web www.generatorjoe.NET

■ Power Switching & Controls
for Business-Critical Continuity

ASCO SERIES 300 Power Transfer Switches



GeneratorJoe

4016 Quartz Drive
Santa Rosa, CA 95405
Phone: 707 539-9003
Fax: 707 539-5212
Email: sales@generatorjoe.NET
Web www.generatorjoe.NET

ASCO®



EMERSON™
Network Power

ASCO[®] SERIES 300

Power Transfer Switches for Power Outage Protection.

Where would you be without a constant flow of electrical power? We often take for granted that power will always be around when we need it. In reality, power failures are very common. And when the power goes out, your business suffers. Power failures are unpredictable. They can occur at any time and for any number of reasons—a bolt of lightning, a power surge, a blackout, an accident or even equipment failure. They come without warning and often at the most inconvenient times.

It's for this reason that many businesses and other entities have invested in emergency power backup systems. Typically, the system consists of an engine generator and an automatic transfer switch (ATS) which transfers the load from the utility to the generator.

An ATS with built-in control logic monitors your normal power supply and senses any interruptions. When the utility power fails, the ATS automatically starts the engine and transfers the load after the generator has reached

proper voltage and frequency. This happens in a matter of seconds after the power failure occurs. When the utility power has been restored, the ATS will automatically switch the load back, and after a time delay, it will shut down the engine. With an Automatic Transfer Switch, you are protected 24 hours a day, seven days a week.



Typical Applications

Telecom

In the telecommunications industry, providing a high level of service and dependability is crucial. Lost power means an interruption in service for your customers and lost business for your company. For instance, with cell sites scattered across a wide geographical region and in many remote areas, the chances of an interruption in power are increased, making Automatic Transfer Switches a valuable resource at each location. To maintain dependable service, each cell site must be monitored 24 hours a day. This can be very difficult without some type of remote monitoring and testing capability. The SERIES 300 Transfer Switch, combined with ASCO's monitoring and control management system, is a cost-effective, packaged solution which can help meet both of these challenging objectives without a major investment at each cell site. With ASCO's connectivity solutions you can remotely monitor and control numerous sites from around the corner or around the world.

Agriculture

Maintaining electrical power is vital to an agriculture operation. If the flow of power is interrupted, your operation could be at risk unless the backup generator is quickly activated. A prolonged power outage can affect numerous aspects of the operation, from housing and feeding livestock to processing and producing the end product. With an ASCO SERIES 300 Transfer Switch, power will automatically be transferred over to your backup generator, eliminating the need to manually switch from utility to generator. When power is restored, the ASCO SERIES 300 Transfer Switch will, after an adjustable time delay to allow for utility stabilization, automatically switch the load back to the utility service.

Commercial / Retail, Light Industrial

The retail industry is very competitive. An electrical power failure can have a dramatic impact on a retailer's bottom line. If power is interrupted during peak shopping times, the effect could be extremely damaging to present and future business. A power interruption will not only suspend shopping, it can also create safety problems, result in lost transaction data, lost account information and damage to data collection equipment. In addition, retailers who rely on controlled climates to protect valuable inventory could suffer even greater losses, especially if the power failure occurs at a time when no one is available to rectify the situation. To avoid any of these power outage problems, simply install a backup generator with an ASCO SERIES 300 Transfer Switch and power outage concerns will be a thing of the past.

Municipal

The ASCO SERIES 300 Transfer Switch can be a critical component of a municipal government's emergency power backup system. Residents of townships, cities and counties rely on police, fire, ambulance/first aid and other critical public sector services. An interruption in power would affect the ability of emergency services to effectively respond to the needs of the community. When time is a critical factor, such as when responding to a fire alarm or an emergency call, an ASCO SERIES 300 Transfer Switch can be a lifesaver, switching power to the backup generator. While not all municipal services are a matter of life and death, they are always expected to be there.



Generator Joe

4016 Quartz Drive
Santa Rosa, CA 95405
Phone: 707 539-9003
Fax: 707 539-5212
Email: sales@generatorjoe.NET
Web www.generatorjoe.NET

Maximum Reliability & Excellent Value

With a SERIES 300 Transfer Switch, you get a product backed by ASCO Power Technologies, the industry leader responsible for virtually every major technological advance in the Transfer Switch industry.

The ASCO SERIES 300 was designed for one purpose—to automatically transfer critical loads in the event of a power outage. Each and every standard component was designed by ASCO engineers for this purpose.

The rugged construction and proven performance of the ASCO SERIES 300 assure the user of many years of complete reliability. The SERIES 300 is even designed to handle the extraordinary demands placed on the switch when starting or restarting stalled motors and switching high inrush loads.

ASCO's SERIES 300 modular, compact design makes it easy to install, inspect and maintain. All parts are accessible from the front so switch contacts can be easily inspected.

Features

- The SERIES 300 is listed to UL 1008 standard for Transfer Switch Equipment and CSA standard C22.2 for automatic transfer switches.
- Meets NFPA 110 for Emergency and Standby Power Systems and the National Electrical Code (NEC) Articles 700, 701 and 702.
- 30 through 3000 amps in a compact design.
- Available to 600 VAC, single or three phase.
- True double-throw operation: The single solenoid design is inherently interlocked and prevents contacts from stopping between sources or from being in contact with both sources at the same time.

UL Listed Withstand & Close-On Ratings

Switch Ratings amps	Available Symmetrical Amperes RMS		
	When Used With Current Limiting Fuses	Maximum Voltage	When Used With Specific Circuit Breakers
30	100,000	480v/60Hz	10,000
70 - 200	200,000	480v/60Hz	22,000
230	100,000	480v/60Hz	22,000
260, 400	200,000	480v/60Hz	42,000
600	200,000	600v/60Hz	42,000
600	200,000	480v/60Hz	50,000
600	200,000	240v/60Hz	65,000
800,1000,1200	200,000	600v/60Hz	65,000
1600, 2000	200,000	600v/60Hz	85,000
2600, 3000	200,000	600v/60Hz	100,000

Notes: 1. Current – limiting fuse should be Class J type through 400 amps: use Class L type above 400 - amp fuse rating
2. Refer to publication 1128 for specific manufacturer's breakers



Fig. 1: ASCO Power Transfer Switch rated 200 amperes shown in Type 3R enclosure

- There's no danger of the SERIES 300 ATS transferring loads to a dead source because the unique ASCO single-solenoid operator derives power to operate from the source to which the load is being transferred.
- Easy-to-read flush-mounted control and display panel provides LED indicators for switch position and source availability. It also includes test and time-delay bypass switches as standard features.
- Standard engine exerciser for weekly automatic testing of engine generator set with or without load.
- Adjustable time-delay feature prevents switch from being activated due to momentary utility power outages and generator dips.
- Supplied with solid neutral termination.
- Optional switched neutral pole available.
- Accessory kits available.
- Available for immediate delivery.
- Now available for service entrance applications. Contact ASCO for assistance.

ASCO[®] SERIES 300 Power Transfer Switches

Designed to Fit Anywhere

The ASCO SERIES 300 product line represents the most compact design of automatic power transfer switches in the industry. With space in electrical closets being at a premium, the use of wall or floor-mounted ASCO Power Transfer Switches assures designers optimum utilization of space.

All transfer switches through 2000 amps are designed to be completely front accessible. This permits the enclosures to be installed flush to the wall and still allows installation of all power cabling and connections from the front of the switch. Cable entrance plates are also standard on the 1600 and 2000 amp units to install optional side-mounted pull boxes for additional cable bending space.



Fig. 2: ASCO Power Transfer Switch rated 200 amperes



Fig. 3: ASCO Power Transfer Switch rated 400 amperes



Fig. 4: ASCO Power Transfer Switch rated 600 Amperes



Fig. 5: ASCO Power Transfer Switch rated 1000 amperes



Fig. 6: ASCO Power Transfer Switch rated 2000 amperes shown in Type 3R enclosure



Fig. 7: ASCO Power Transfer Switch rated 3000 amperes

ASCO[®] SERIES 300 Microprocessor Controller

The ASCO Microprocessor Controller is used with all sizes of Power Transfer Switches. It represents the most reliable microprocessor controller in the industry and includes, as standard, all of the voltage, frequency, control, timing and connectivity functions required for most emergency and standby power applications.



Fig. 8: ASCO SERIES 300 Microprocessor Controller

Voltage & Frequency Sensing

- Adjustable three-phase, close-differential voltage sensing on normal source.
- Normal source pickup voltage is adjustable to 95% of nominal; drop-out is adjustable from 70% to 90% of nominal.
- Frequency sensing on emergency source. Pickup at 95% and dropout at 85% of nominal.

Time Delays

- Adjustable time delay to override momentary normal source outages to delay all transfer switch and engine-starting signals.
- Transfer to emergency time delay—Adjustable from 0 to 5 minutes for controlled timing of load transfer to emergency.
- Retransfer to normal time delay—Adjustable to 30 minutes.
- Five-minute unloaded running time delay for emergency engine generator cool down.
- Four-second time delay to ignore momentary voltage and frequency transients during initial genset loading.

Standard Selectable Features

- Inphase monitor to transfer motor loads, without any intentional off time, to prevent inrush currents from exceeding normal starting levels.
- Engine exerciser to automatically test backup generator each week—Includes control switch for testing with or without load.
- Selective load disconnect, double-throw contact to operate at an adjustable 0 to 20 second adjustable time delay prior to transfer and reset 0 to 20 seconds after transfer.
- 60 Hz or 50 Hz selectable switch.
Three-phase/single-phase selectable switch.

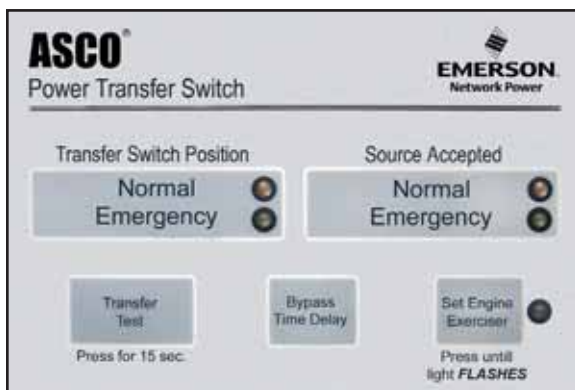

Fig. 9: Door-Mounted Control & Display Panel

Control and Display Panel

- Easy-to-read flush-mounted control and display panel provides LED indicators for switch position and source availability. It also includes test and time-delay bypass switches.



GeneratorJoe

Remote Control Features

Terminal provisions for connecting:

- Remote test switch.
- Remote contact for test or for peak shaving applications. Circuit will be automatically bypassed if emergency source fails.
 - Inhibit transfer to emergency.
 - Remote time-delay bypass switch.

4016 Quartz Drive
Santa Rosa, CA 95405
Phone: 707 539-9003
Fax: 707 539-5212

Email: sales@generatorjoe.NET
Web www.generatorjoe.NET

ASCO® SERIES 300 Microprocessor Controller

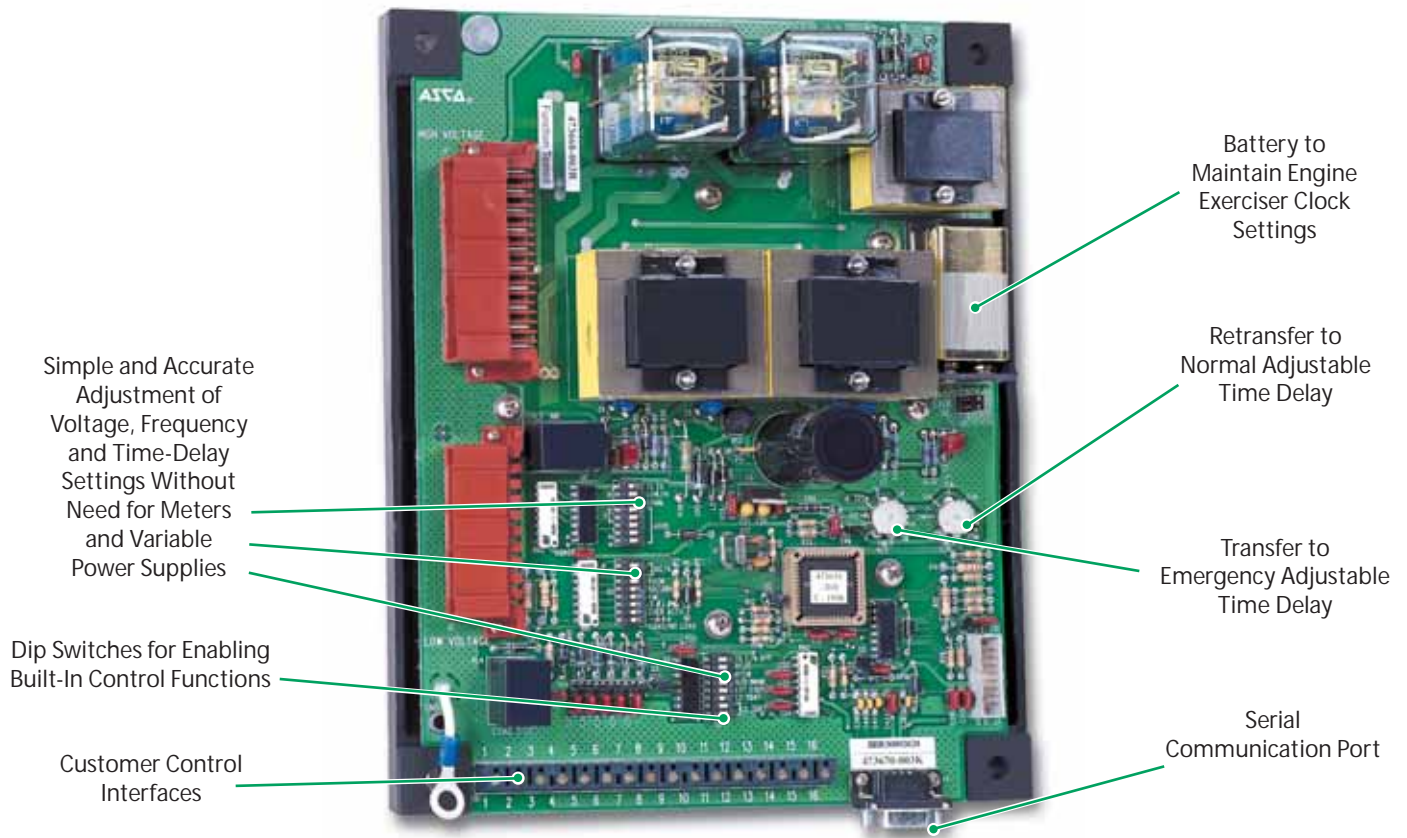

Fig. 10: Microprocessor Controller

Performance Features

- 600 volt spacing per UL and CSA standards.
- Interfacing relays are industrial grade, plug-in type with dust covers.
- Meets or exceeds the requirements for Electromagnetic Compatibility (EMC).
 - ANSI C37.90A/IEEE472 Voltage Surge Test
 - NEMA ICS-109.21 Impulse Withstand Test
 - Digital circuitry isolated from line voltages
 - IEC 801-2 Electrostatic discharge (ESD) immunity
 - ENV50140 and IEC 803-1: Radiated electromagnetic field immunity
 - IEC 801-4 Electrical fast transient (EFT) immunity
 - ENV50142 Surge transient immunity
 - ENV50141: Conducted radio-frequency field immunity
 - EN55011: Group 1, Class A conducted and radiated emissions
 - Optically isolated RS-485 Serial Port
 - EN61000- 4-11 voltage dips and interruptions immunity



GeneratorJoe

4016 Quartz Drive
 Santa Rosa, CA 95405
 Phone: 707 539-9003
 Fax: 707 539-5212
 Email: sales@generatorjoe.NET
 Web www.generatorjoe.NET

ASCO® SERIES 300 ATS Optional Accessories

Accessory 11BG

A programmable engine exerciser that provides for weekly or bi-weekly operation, includes one form C contact for source availability of normal and one contact for availability of emergency (contact rating 2 amps @ 30 Vdc, 0.5 amp @ 125 Vac resistive). The programmable engine exerciser incorporates a 7 day or 14 day time base with a digital readout display. Includes "with or without" load control selection for exerciser period.

Accessory 14AA/14BA

Auxiliary contacts to indicate position of main contacts. Two (2) for normal and two (2) for emergency position (one set is standard).

Accessory 44A

Strip Heater with thermostat for extremely cold areas to prevent condensation and freezing of this condensation. External 120 volt power source required.

Accessory 44G

Strip Heater with thermostat, wired to load terminals: 208-240, 360-380, 460-480, 550-600 volts. Contains wiring harnesses for all transfer switch sizes.

Accessory 72A/72E

*See "Power Connectivity Products", Page 18

Accessory 123

A protective window that includes a polycarbonate frame and weather gasket to provide secure access to the membrane interface for the type 1 enclosures. This lockable cover is an alternative to providing 3R secure enclosures.



Fig. 11: Programmable Engine Exerciser with Source Availability Contacts (Accessory 11BG)



Fig. 12: Strip Heater Kit (Accessory 44G)

Field Conversion Kits for SERIES 300 Transfer Switches

Kit No.	Description
K629830	Engine Exerciser and source availability contacts (Acc. 11BG)
K613127-001	Strip Heater Kit (125 watt) 120 volt (Acc. 44A)
K613127-002	Strip Heater Kit (125 watt) 208-480 volt (Acc. 44G)
K609027	Cable Pull Box (1600-2000 amp)
K473872-001	6 FT Extension Harness ¹
K755257-001	Serial Module with or without power manager (Acc. 72A)
K754603-001	Connectivity Module with or without power manager (Acc. 72E)
K778330-001	Window Kit (Acc. 123)

1. For 30-200 Amp switches only, not available for 300SE, or 300L



Fig. 13: Window Kit (Accessory 123)



GeneratorJoe

4016 Quartz Drive
 Santa Rosa, CA 95405
 Phone: 707 539-9003
 Fax: 707 539-5212
 Email: sales@generatorjoe.NET
 Web www.generatorjoe.NET

ASCO[®] SERIES 386 Non-Automatic Power Transfer Switches

User-Initiated Control

ASCO 386 non-automatic transfer switches are generally used in applications where operating personnel are available and the load is not an emergency type requiring automatic transfer of power. The power-switching mechanism and controller is the same hardware used on the highly reliable ASCO SERIES 300 transfer switches. ASCO 386s are furnished as standard with a momentary-type selector switch to initiate transfer and retransfer. They can also be arranged for remote control via ASCO's connectivity products.



Fig. 14: ASCO 386 400 Amp Type 1 Enclosure w/Optional Accessories 9C, 9D Source Availability Lights

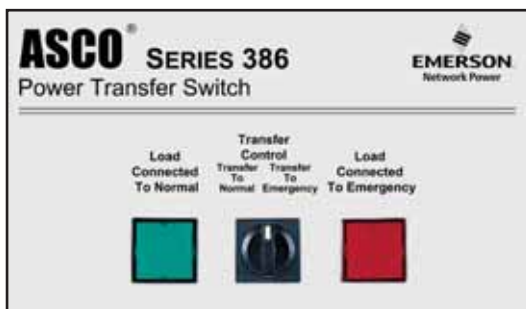

Fig. 15: Control and Display Panel

Electrical Features:

- Listed under UL 1008, CSA certified:
 - UL listed through 480 VAC.
 - CSA certified through 600 VAC.
- Door-mounted selector switch for local, manually initiated electrical control.
- Sizes from 30 through 3000 amps. Available to 600 VAC, 50 or 60 Hz.
- Rated for all classes of load transfer. 100% tungsten load ratings through 400 amps.
- Designed for emergency and standby applications.
- Same withstand and close-on rating as SERIES 300.

Standard Selectable Control Features:

- Inphase monitor to transfer motor loads between live sources, without any intentional off time, to prevent inrush currents from exceeding normal starting levels.
- Selective load disconnect, double-throw contact to operate at an adjustable 0 to 20 second time delay prior to transfer and reset 0 to 20 seconds after transfer.
- High/Low nominal voltage setting. Allows user to adjust for source low reduced voltage conditions in remote areas.
- 60 Hz or 50 Hz selectable switch.
- Single/Three-phase selectable switch.

Control Features:

- Switch position indicating signal lights.
- One auxiliary contact closed when transfer switch is connected to normal and one closed on emergency, standard feature 14A/14B.

Optional Accessories:

- 6Q Key-operated, momentary source selector switch furnished instead of the standard selector switch.
- 9C, 9D Source availability lights to provide operator with a local indication of power source availability.
- Accessory 14AA/14BA auxiliary contacts to indicate position of main contacts. Two (2) for normal position and two (2) for emergency position (one set is standard).
- 72A Serial module (5110) is used to allow local or remote communications with ASCO PowerQuest[®] VPi or SiteWeb[™] connectivity products.
- Special Enclosures (Specify by appropriate code in catalog number):
 - Type 3R: Raintight
 - Type 4: Weatherproof
 - Type 12: Oil Tight
- 72E Connectivity Module 5150 is used to bring several different serial devices that communicate at different baud rates and with different protocols to a common Ethernet media.

ASCO[®] SERIES 300 & 386 Transfer Switch Ordering Information

To order an ASCO SERIES 300 Power Transfer Switch, complete the following catalog number:

300 + B + 3 + 600 + N + 1 + X + C + 11CD + 480V 60Hz											
Product	Neutral Code	Poles	Amperes	Voltage Code		Controller	Options	Enclosure		Optional Accessories	Specific Volt & Freq
				A ³	B ³			Blank	Open Type		
300	Blank Solid Neutral B ¹ Switched Neutral	2 poles, 1Ø 3 poles, 3Ø	Continuous rating 30, 70, 104, 150, 200 ⁴ , 230 ⁴ , 260, 400, 600, 800, 1000, 1200, 1600, 2000 2600 ⁵ , 3000 ⁵	A ³	115 120 208 220 230 240 380 400 415 440 460 480 575 600	1	Insert "X" If optional accessories are required	C	Type 1 (Standard)	11BG Programmable Engine Exerciser 14AA/14BA Auxiliary Contacts (2 sets) 44A, 44G Strip Heater w/Thermostat 72A Serial Module 72E Connectivity Module 123 Window Kit	This information is necessary to allow correct control settings prior to shipment
				C				F	Type 3R Enclosure		
				D				G	Type 4 Enclosure ²		
				E				H	Type 4X Enclosure		
				F				L	Type 12 Enclosure ²		
				H				M	Type 3R Secure Enclosure		
				J				N	Type 4 Secure Enclosure		

To order an ASCO SERIES 386 Transfer Switch, complete the following catalog number:

386 + B + 3 + 600 + N + 1 + X + C + 9C/9D + 480V 60Hz											
Product	Neutral Code	Phase Poles	Amperes	Voltage Code		Controller	Options	Enclosure		Optional Accessories	Specific Volt & Freq
				A ³	B ³			Blank	Open Type		
386	A Solid Neutral B ¹ Switched Neutral	2 poles, 1Ø 3 poles, 3Ø	Continuous rating 30, 70, 100, 150, 200 ⁴ , 230 ⁴ , 260, 400, 600, 800, 1000, 1200, 1600, 2000, 2600, 3000 ⁵	A ³	115 120 208 220 230 240 380 400 415 440 460 480 575 600	1	Insert "X" If optional accessories are required	C	Type 1 (Standard)	6Q Key-Operated Control 9C/9D Source Availability Lights 14AA/14BA Auxiliary Contacts 72A Serial Module All Accessories 72E Connectivity Module	This information is necessary to allow correct control settings prior to shipment
				C				F	Type 3R Enclosure		
				D				G	Type 4 Enclosure ²		
				E				H	Type 4X Enclosure		
				F				L	Type 12 Enclosure ²		
				H				M	Type 3R Secure Enclosure		

- Notes:**
1. Specify neutral code "C" for 260 and 400 amperes only.
 2. Available 30-1000, and 1600 amps. Use Type 3R for 1200, 2000, 2600 and 3000 amp applications.
 3. 115-120 volt available 30-400 amps only. For other voltages contact ASCO.
 4. 200 and 230 amp rated switches for use with copper cable only.
 5. Secure 3R type provided as standard for 2600-3000 amp when outdoor enclosure is required.

Extended Warranties for SERIES 300 Transfer Switches

Catalog No.	Description
2EXW300	Two-Year Extended Warranty (Parts & Labor)
3EXW300	Three-Year Extended Warranty (Parts & Labor)
4EXW300	Four-Year Extended Warranty (Parts & Labor)
5EXW300	Five-Year Extended Warranty (Parts & Labor)

ASCO[®] SERIES 300 & 386 Transfer Switch Dimensions and Shipping Weights

UL Type 1 Enclosure⁴

	Phase Poles	Neutral Code	Dimensions, In. (mm)			Approx. Shipping Weight Lb. (kg)
			Width	Height	Depth	
30, 70, 100*, 104 150, 200 *SERIES 386 only	2	A	17 1/2 (445)	31 (787)	11 5/8 (295)	69 (32)
	2	B	17 1/2 (445)	31 (787)	11 5/8 (295)	73 (33)
	3	A	17 1/2 (445)	31 (787)	11 5/8 (295)	73 (33)
	3	B	17 1/2 (445)	31 (787)	11 5/8 (295)	75 (34)
230 ³ , 260, 400	2	A	18 (457)	48 (1219)	13 (330)	100 (45)
	2	B ³ or C	18 (457)	48 (1219)	13 (330)	110 (50)
	3	A	18 (457)	48 (1219)	13 (330)	100 (45)
	3	B ³ or C	18 (457)	48 (1219)	13 (330)	120 (55)
600	2	A	24 (610)	63 (1600)	17 (432)	263 (119)
	2	B	24 (610)	63 (1600)	17 (432)	270 (122)
	3	A	24 (610)	63 (1600)	17 (432)	270 (122)
	3	B	24 (610)	63 (1600)	17 (432)	277 (126)
800, 1000	2	A	34 (864)	72 (1829)	20 (508)	450 (204)
	2	B	34 (864)	72 (1829)	20 (508)	475 (217)
	3	A	34 (864)	72 (1829)	20 (508)	475 (217)
	3	B	34 (864)	72 (1829)	20 (508)	500 (228)
1200	2	A	38 (965)	87 (2210)	24 (610)	685 (312)
	2	B	38 (965)	87 (2210)	24 (610)	705 (321)
	3	A	38 (965)	87 (2210)	24 (610)	705 (321)
	3	B	38 (965)	87 (2210)	24 (610)	725 (328)
1600, 2000 ¹	3	A	38 (965)	87 (2210)	24 (610)	925 (419)
	3	B	38 (965)	87 (2210)	24 (610)	975 (441)
2600, 3000 ²	3	A	38 (965)	91 (2311)	60 (1524)	1700 (771)
	3	B	38 (965)	91 (2311)	60 (1524)	2135 (969)

Notes:

- Unit is designed for top cable entry of emergency & load and bottom entry of normal. A cable pull box is also available for all top or bottom cable access when required (optional accessory kit #K609027). Not required for type 3R, 4X & 12 enclosures where available.
- Enclosures for 2600, 3000 amps are free-standing with removable top, sides & back.
- Neutral Code "B" for 230 amperes only.
- Dimensional data is approximate and subject to change. Certified dimensions available upon request.

UL Type 3R, 4 or 12 Enclosure^{1,4,5,6}

Switch Rating amps	Phase Poles	Neutral Code	Dimensions, In. (mm)			Approx. Shipping Weight Lb. (kg)
			Width	Height	Depth	
30, 70, 100*, 104 150, 200 *SERIES 386 only	2	A	17 1/2 (445)	35 (886)	11 5/8 (295)	84 (38)
	2	B	17 1/2 (445)	35 (886)	11 5/8 (295)	87 (40)
	3	A	17 1/2 (445)	35 (886)	11 5/8 (295)	87 (40)
	3	B	17 1/2 (445)	35 (886)	11 5/8 (295)	90 (41)
230 ³ , 260, 400	2	A	18 (458)	50 1/2 (1284)	14 1/3 (364)	132 (60)
	2	B ³ or C	18 (458)	50 1/2 (1284)	14 1/3 (364)	140 (63)
	3	A	18 (458)	50 1/2 (1284)	14 1/3 (364)	140 (63)
	3	B ³ or C	18 (458)	50 1/2 (1284)	14 1/3 (364)	148 (67)
600	2	A	40 (1017)	75 (1907)	26 (661)	664 (300)
	2	B	40 (1017)	75 (1907)	26 (661)	672 (303)
	3	A	40 (1017)	75 (1907)	26 (661)	672 (303)
	3	B	40 (1017)	75 (1907)	26 (661)	680 (307)
800, 1000	2	A	40 (1017)	75 (1907)	26 (661)	664 (300)
	2	B	40 (1017)	75 (1907)	26 (661)	672 (303)
	3	A	40 (1017)	75 (1907)	26 (661)	672 (303)
	3	B	40 (1017)	75 (1907)	26 (661)	680 (307)
1200 ⁶	2	A	41 (1043)	94 1/2 (2403)	33 1/2 (852)	1131 (513)
	2	B	41 (1043)	94 1/2 (2403)	33 1/2 (852)	1160 (526)
	3	A	41 (1043)	94 1/2 (2403)	33 1/2 (852)	1160 (526)
	3	B	41 (1043)	94 1/2 (2403)	33 1/2 (852)	1189 (539)
1600, 2000 ²	3	A	41 (1043)	95 1/2 (2428)	62 (1577)	1810 (817)
	3	B	41 (1043)	95 1/2 (2428)	62 (1577)	1860 (843)
2600, 3000	3	A	41 (1043)	95 1/3 (2424)	74 (1882)	2005 (905)
	3	B	41 (1043)	95 1/3 (2424)	74 (1882)	2070 (938)

Notes:

- 30-1000 amps non-secure enclosure. 1200-3000 amps secure enclosure
- When temperature below 32°F can be experienced, special precautions should be taken, such as the inclusion of space heaters, to prevent condensation and freezing of this condensation.
- Neutral code "B" for 230 amperes only.
- Dimensions for switch sizes 30 - 1000 amperes suitable for Type 3R, 4, or 12 non secure enclosure, 1200 -3000 amperes only suitable for type 3R.
- For 1200 ampere type 4, or 12 use 1600 amperes secure enclosure dimensions.
- Dimensional data is approximate and subject to change. Certified dimensions available upon request.

ASCO[®] SERIES 300 & 386 External Power Connections

Sizes UL-Listed Solderless Screw-Type Terminals

Switch Rating (amps)	Ranges of AL-CU Wire Sizes (Unless Specified Copper Only)
30 - 230 ²	One #14 to 4/0 AWG
260, 400	Two 1/0 AWG to 250 MCM or One #4 AWG to 600 MCM
600	Two 2/0 AWG to 600 MCM
800, 1000, 1200	Four 1/0 to 600 MCM
1600, 2000	Six 1/0 to 600 MCM
2600, 3000	Twelve 3/0 to 600 MCM

Notes:

- All SERIES 300 switches are furnished with a solid neutral plate (unless switched neutral configuration is specified) and terminal lugs. Specify "A" in catalog number to order a neutral plate on the series 386 switches.
- 200 and 230 amp rated switches for use with copper cable only. Refer to paragraph 310.15 of the NEC for additional information.
- Use wire rated 75°C minimum for all power connections.

ASCO[®] SERIES 300SE Power Transfer Switch



Fig. 16: ASCO Service Entrance Power Transfer Switch rated 3 Pole 800 amperes shown in Type 3R enclosure

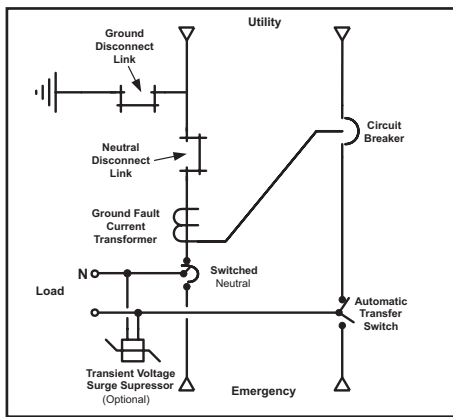

One line diagram of a typical service entrance rated transfer switch available in Solid or Switched Neutral. *Ground fault trip protection provided on sizes of 1000 amperes and above

The ASCO Service Entrance Power Transfer Switch

Combines automatic power switching with a utility circuit breaker as a disconnect device. The power transfer switch meets all National Electrical Code requirements for installation as service entrance equipment.

Service entrance rated transfer switches generally are installed at facilities that have a single utility feed and a single emergency power source. A circuit breaker serves as the utility disconnect and links are provided to connect both neutral and ground conductors.

The ASCO 300SE Service Entrance Automatic Transfer Switch uses the same reliable transfer switching mechanism and controller as the SERIES 300 product platform, and also includes a utility circuit breaker as a disconnect device.

Product Features:

- Suitable for use as service entrance equipment.
- The ASCO SERIES 300SE is listed to UL 891 standard for Dead-Front Switchboards, and meets all NEC requirements for service entrance equipment.
- Automatic Transfer Switch is listed to UL 1008 for total system loads.
- Sizes available from 70 through 3000 amps. Available to 600 VAC, 50 or 60Hz, single or three phase.
- Circuit Breaker disconnect on the normal for isolation of transfer switch and other electrical equipment.
- Disconnect link on Neutral and Ground. Silver plated copper ground and neutral bus.
- Solderless screw type terminals for External Power Connections.
- Ground fault trip protection provided on sizes of 1000 amperes and above.
- UL approved Type 1 enclosure.
- UL approved Type 3R secure enclosure.
- Available with solid or switched neutral.
- Optional TVSS Available on Normal, Emergency and/or Load.



Fig. 17: ASCO Service Entrance Power Transfer Switch rated 2 pole 200 amperes shown in reduced type 3R enclosure where space is limited

ASCO[®] SERIES 300SE Transfer Switch Ordering Information

To order an ASCO SERIES 300SE Power Transfer Switch, complete the following catalog number:

3AUS + B + 3 + 400 + N + 1 + X + C + 11CD + 240V/60											
Product	Neutral Code	Phase Poles	Amperes Continuous Rating	Voltage Code		Controller	Options	Enclosure		Optional Accessories	Specific Volt & Freq
				A ³	B ³			Blank	Open Type		
3AUS	B ¹ Switched Neutral	2 poles, 1Ø 3 poles, 3Ø	70, 100, 150, 200 ⁹ , 225 ⁹ , 250, 400, 600, 800, 1000, 1200, 1600, 2000 2500, 3000	A ³	115	1	Insert "X" If optional accessories are required	C	Type 1 (Standard)	11BG Programmable Engine Exerciser	This information is necessary to allow correct control settings prior to shipment
				B ³	120			M	Type 3R Secured Enclosure	14AA/14BA Auxiliary Contacts (2 sets)	
				C	208			N	Type 4 Secured Enclosure ²	44G Strip Heater w/Thermostat	
				D	220			Q	Type 12 Secured Enclosure ²	72A Serial Module	
				E	230					72E Connectivity Module	
				F	240					73A Surge Suppressor	
				H	380					42TH ⁵ Reduced Type 3R Secured	
				J	400						
				K	415						
				L	440						

Notes: 1. Specify neutral code "C" for 250 and 400 amperes only.
 2. Available 70-1000 ampacity. Use Type 3R for 1200-3000 amp applications.
 3. 115-120 volt available 150-400 amps only.
 4. A solid neutral is standard on 3AUS.
 5. For switch sizes 70 - 225 amperes only
 6. 200, 225 amp rated switch suitable for use with copper cable only.

ASCO® SERIES 300SE Transfer Switch Dimensions and Shipping Weights

UL Type 1 Enclosure²

Switch Rating amps	Phase Poles	Neutral Code	Dimensions, In. (mm)			Approx. Shipping Weight Lb. (kg)
			Width	Height	Depth	
70, 100, 150, 200, 225	2	STD	36.5 (927)	48.5 (1232)	13.25 (337)	400 (185)
	2	B	36.5 (927)	48.5 (1232)	13.25 (337)	408 (188)
	3	STD	36.5 (927)	48.5 (1232)	13.25 (337)	408 (188)
	3	B	36.5 (927)	48.5 (1232)	13.25 (337)	416 (192)
250, 400	2	STD	36.5 (927)	48.5 (1232)	13.25 (337)	400 (185)
	2	C	36.5 (927)	48.5 (1232)	13.25 (337)	408 (188)
	3	STD	36.5 (927)	48.5 (1232)	13.25 (337)	408 (188)
	3	C	36.5 (927)	48.5 (1232)	13.25 (337)	416 (192)
600 ¹ , 800 ¹	2	STD	38 (965)	91 (2311)	28 (711)	800 (370)
	2	B	38 (965)	91 (2311)	28 (711)	820 (378)
	3	STD	38 (965)	91 (2311)	28 (711)	820 (378)
	3	B	38 (965)	91 (2311)	28 (711)	846 (390)
1000 ¹ , 1200 ¹	2	STD	38 (965)	91 (2311)	48 (1218)	1085 (501)
	2	B	38 (965)	91 (2311)	48 (1218)	1105 (510)
	3	STD	38 (965)	91 (2311)	48 (1218)	1105 (510)
	3	B	38 (965)	91 (2311)	48 (1218)	1134 (523)
1600 ¹ , 2000 ¹	3	STD	38 (965)	91 (2311)	48 (1218)	2590 (1198)
	3	B	38 (965)	91 (2311)	48 (1218)	2640 (1218)
2500 ¹ , 3000 ¹	3	STD	38 (965)	91 (2311)	72 (1829)	4590 (2118)
	3	B	38 (965)	91 (2311)	72 (1829)	4655 (2148)

- Notes:** 1. Unit is designed for top and bottom cable entry for all services and load.
2. Dimensional data is approximate and subject to change. Certified dimensions available upon request.

UL Type 3R Enclosure⁵

Switch Rating amps	Phase Poles	Neutral Code	Dimensions, In. (mm)			Approx. Shipping Weight Lb. (kg)
			Width	Height	Depth	
70, 100, 150, 200, 225 must specify accessory 42TH3 ⁴	2	STD	24(609) ⁴	37.25(946) ⁴	12 (304) ⁴	180 (83)
	2	B	24(609) ⁴	37.25(946) ⁴	12 (304) ⁴	188 (87)
	3	STD	24(609) ⁴	37.25(946) ⁴	12 (304) ⁴	188 (87)
	3	B	24(609) ⁴	37.25(946) ⁴	12 (304) ⁴	196 (90)
250, 400	2	STD	36.5 (927)	49.25 (1251)	16 (406)	538 (248)
	2	C	36.5 (927)	49.25 (1251)	16 (406)	546 (252)
	3	STD	36.5 (927)	48.25 (1251)	16 (406)	546 (252)
	3	C	36.5 (927)	48.25 (1251)	16 (406)	554 (256)
600 ¹ , 800 ¹	2	STD	38 (965)	91 (2311)	36.25 (921)	990 (458)
	2	B	38 (965)	91 (2311)	36.25 (921)	1010 (467)
	3	STD	38 (965)	91 (2311)	36.25 (921)	1010 (467)
	3	B	38 (965)	91 (2311)	36.25 (921)	1036 (479)
1000 ¹ , 1200 ¹	2	STD	40 (1016)	91 (2311)	62 (1575)	1305 (604)
	2	B	40 (1016)	91 (2311)	62 (1575)	1325 (613)
	3	STD	40 (1016)	91 (2311)	62 (1575)	1325 (613)
	3	B	40 (1016)	91 (2311)	62 (1575)	1354 (626)
1600 ¹ , 2000 ¹	3	STD	41 (1041)	95 (2413)	62 (1575)	2890 (1337)
	3	B	41 (1041)	95 (2413)	62 (1575)	2940 (1360)
2500 ¹ , 3000 ¹	3	STD	41 (1041)	95.5 (2426)	74 (1880)	5350 (2474)
	3	B	41 (1041)	95.5 (2426)	74 (1880)	5415 (2504)

- Notes:** 1. Unit is designed for top and bottom cable entry for all services and load.
2. Enclosures for 600 – 3000 amps are freestanding.
3. When temperatures below 32° F can be experienced, special precautions should be taken, such as the inclusion of strip heaters, to prevent condensation and freezing of this condensation. This is particularly important when environmental enclosures

- (Type 3R, 4 & 12) are ordered for installation outdoors. See Optional Accessories page for space heater options (acc. 44G).
4. If accessory 44G is specified for 70-225 amps an oversize enclosure is required. W - 36.5(927), H - 49.25 (1251), D - 16 (406)
Weight : 554(256)
5. Dimensional data is approximate and subject to change. Certified dimensions available upon request.

Extended Warranties for SERIES 300SE Transfer Switches

Catalog No.	Description
2EXW300SE	Two-Year Extended Warranty (Parts & Labor)
3EXW300SE	Three-Year Extended Warranty (Parts & Labor)
4EXW300SE	Four-Year Extended Warranty (Parts & Labor)
5EXW300SE	Five-Year Extended Warranty (Parts & Labor)

SERIES 300SE AIC Rating

Switch Rating	AIC Rating
70, 100, 150, 200, 225	25,000
250, 400	35,000
600, 800, 1000, 1200, 1600, 2000	65,000
2500, 3000	100,000

SERIES 300SE External Power Connections Sizes UL-Listed Solderless Screw-Type Terminals

Switch Rating	Ranges of AL-CU Wire Sizes (Unless Specified Copper Only)
70, 100, 150, 200*, 225*	One #14 to 4/0 AWG
250, 400	Two 1/0 AWG to 250 MCM or One #4 AWG to 600 MCM
600	Two 1/0 AWG to 600 MCM
800, 1000, 1200	Four 1/0 to 600 MCM
1600, 2000	Six 1/0 to 600 MCM
2500	Twelve 3/0 to 600 MCM
3000	Twelve 3/0 to 600 MCM

- Note:** All SERIES 300SE switches are furnished with a solid neutral plate (unless switched neutral configuration is specified) and terminal lugs.
* 200 and 225 amp rated switch for use with copper cable only.



Fig. 18: SERIES 300 L Power Transfer Load Center

The ASCO Power Transfer Load Center

Everything that is needed to protect sensitive loads from power outages and transients is in one package, the ASCO SERIES 300 Automatic Power Transfer Switch with microprocessor digital controller. Versatile Square D Load Distribution Panel, and protective transient voltage surge suppression for normal and emergency.

ASCO Automatic Transfer Switches are the standard of the industry and represent the most advanced technology in transferring loads between two power sources.

Available with 200 or 400 Amp rating, 120/240 VAC 60 hz single phase, 3 wire or 120/208 VAC, 60 hz three phase, 4 wire.

The PTLC includes a 42-position load distribution panel. Main circuit breakers provide overcurrent protection and disconnect for convenient and safe serviceability. The shallow profile facilitates installation.

When power fails, the automatic transfer switch follows user-set time delays to start the generator, transfer the load to the generator, reconnect to utility power and shut down the generator after generator cool down.

Features

- Power Transfer Load Center is Service Entrance Rated and listed to UL67
- Automatic Transfer Switch is listed to UL1008, the standard for Transfer Switch Equipment, and meets NFPA 110 for Emergency and Standby Power Systems and the National Electrical Code (NEC) articles 700, 701 and 702. Also CSA certified to CSA 22.2 No. 178-1978
- True double-throw contacts eliminate simultaneous connection to utility and generator
- Adjustable close differential voltage sensing on the normal source
- Automatic engine exerciser to test the generator with or without loads. This is optional accessory 11BG on standard SERIES 300 products
- Pre-wired and factory tested for easy installation
- Space saving modular design provides easy access and serviceability
- Convenient terminals for connecting neutral and ground conductors
- Available in Type 1 (indoor) or Type 3R (non-secure outdoor) enclosures

Transient Voltage Surge Suppression (TVSS)

Technology

Parallel Arrayed Metal Oxide Varistors

Maximum continuous operating voltage (MCOV)

125 Percent of Line Voltage

Mode Protection

All mode protection (L-N, L-G, L-L, N-G)

Surge Current

90kA (8/20us) Transient waveform for category C

Surge Voltage Rating

(8/20us), 400v (L-N, L-G, N-G, 700volts (L-L)

OverCurrent Protection

200 amps

400 amps

Alarming

Remote - Two (2) Form C contacts rated 5 amps at 120 vac

Visual - LED protection indicators for each phase

Optional Features

- Three source arrangement (stationary and portable generators)
- Generator single pole receptacles
- Generator multipole receptacle



GeneratorJoe

4016 Quartz Drive
Santa Rosa, CA 95405
Phone: 707 539-9003
Fax: 707 539-5212

Email: sales@generatorjoe.NET
Web www.generatorjoe.NET

ASCO[®] SERIES 300L Power Transfer Load Center Ordering Information

To order an ASCO SERIES 300L Power Transfer Load Center, complete the following catalog number:

300L + 4 + 2 + 200 + F + 1 + X + C									
Product	Load Center	Poles	Amperes Continuous Rating	Voltage Code		Controller	Options	Enclosure	
				C	F			C	F
300L	4 = 42 Circuits	2 poles, 1Ø 3 poles, 3Ø	200 400	C	208/120v/60hz 3Ø 4 wire	1	Insert "X" If optional accessories are required 11BG Programmable Engine Exerciser and Source Availability Contacts 14AA/14BA Auxiliary Contacts¹ 44G Strip Heater w/Thermostat 72A Serial Module 72E Connectivity Module 73 Transient Voltage Surge Suppression 73V*1² single phase or 73V*3² three phase	C	Type 1 (Standard)
				F	240/120v/60hz 1Ø 3 wire			F	Type 3R Secure

- Notes:**
1. Auxiliary contacts indicate position of main contacts. Two (2) for normal and two (2) for emergency position (one set is standard)
 2. Specify N for Utility (1 required), B for Utility and Generator (2 are required), and L for Load (1 required)

ASCO[®] SERIES 300L Power Transfer Load Center Dimensions and Shipping Weights¹

Switch Rating amps	Phase Poles	Enclosure Type	Dimensions², In. (mm)			Approx. Shipping Weight Lb. (kg)
			Width	Height	Depth	
200	2	Type 1	30 (762)	66 (1675)	6 (152)	255 (118)
200	3	Type 1	30 (762)	66 (1675)	6 (152)	259 (120)
200	2	Type 3R Non Secure	30 (762)	84 (2133)	10 (254)	317 (146)
200	3	Type 3R Non Secure	30 (762)	84 (2133)	10 (254)	321 (148)
400	2	Type 1	35 (888)	78 (1980)	7.25 (184)	290 (134)
400	3	Type 1	35 (888)	78 (1980)	7.25 (184)	298 (138)
400	2	Type 3R Non Secure	30 (762)	84 (2133)	10 (254)	352 (163)
400	3	Type 3R Non Secure	30 (762)	84 (2133)	10 (254)	360 (166)

Note: 1. Dimensional data is approximate and subject to change. Certified dimensions available upon request.

SERIES 300L Power Transfer Load Center Sizes UL-Listed Solderless Screw-Type Terminals

Switch Rating	Ranges of AL-CU Wire Sizes (Unless Specified Copper Only)
200	One #14 to 4/0 AWG
400	Two 1/0 AWG to 250 MCM or One #4 AWG to 600 MCM

Extended Warranties for SERIES 300L Power Transfer Center Switches

Catalog No.	Description
2EXW300L	Two-Year Extended Warranty (Parts & Labor) Total 2 years
3EXW300L	Three-Year Extended Warranty (Parts & Labor) Total 3 years
4EXW300L	Four-Year Extended Warranty (Parts & Labor) Total 4 years
5EXW300L	Five-Year Extended Warranty (Parts & Labor) Total 5 years

Note: 1. Consult ASCO for Type 3R secure enclosures

Field Conversion Kits for SERIES 300L Transfer Switches

Kit No.	Description
K733433-001	Single Phase Surge Suppression 240v/120v (Acc. 73V*1)
K733433-003	Three Phase Surge Suppression 209v/120v (Acc. 73V*3)



4016 Quartz Drive
 Santa Rosa, CA 95405
 Phone: 707 539-9003
 Fax: 707 539-5212
 Email: sales@generatorjoe.NET
 Web www.generatorjoe.NET

ASCO® SERIES 300 Power Monitoring & Control

ASCO Connectivity Solutions

ASCO PowerQuest® and SiteWeb® communications products allow for the monitoring and control of power transfer switches in your Emergency or Standby Power Distribution System. Local Area Networks and Remote networks are supported with either single or multiple points of access and web-enabled communications allow access to your power system from anywhere around the world.

Features

- Monitors and controls Power Transfer Switches and Engine Generators
- Monitors normal and emergency voltages and frequency
- Indicates transfer switch position and source availability
- Provides transfer and re-transfer of loads for system testing
- View normal and emergency voltage and frequency settings
- View transfer switch time-delay settings
- Provides transfer switch rating and identification
- Automatic paging notifies personnel, by e-mail or text message, of selected system alarms
- View current, power and power factor with ASCO Power Managers connected to the system

PowerQuest® Typical Network Connection

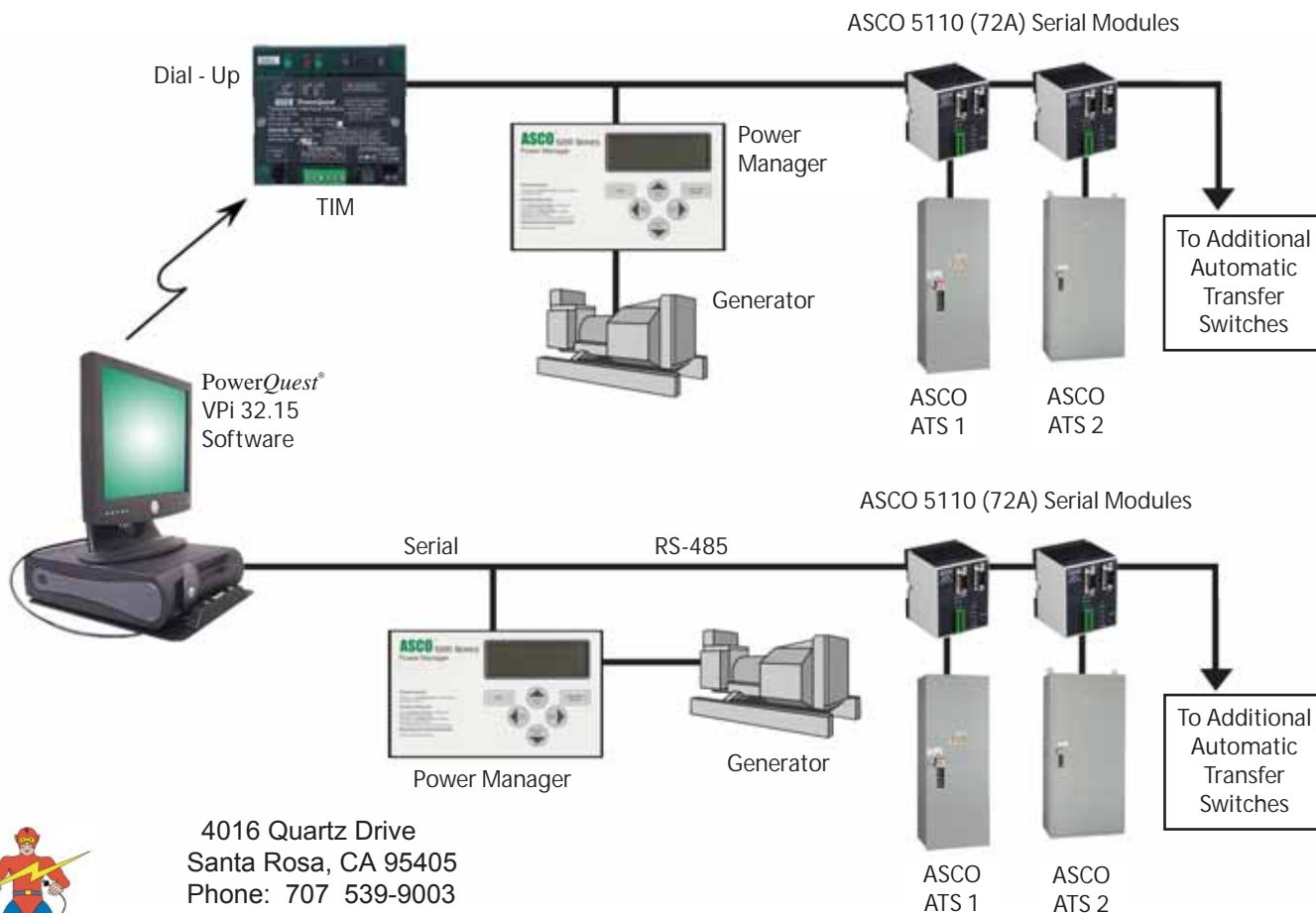

4016 Quartz Drive
 Santa Rosa, CA 95405
 Phone: 707 539-9003
 Fax: 707 539-5212
 Email: sales@generatorjoe.NET
 Web www.generatorjoe.NET

GeneratorJoe

ASCO® SERIES 300 Power Monitoring & Control

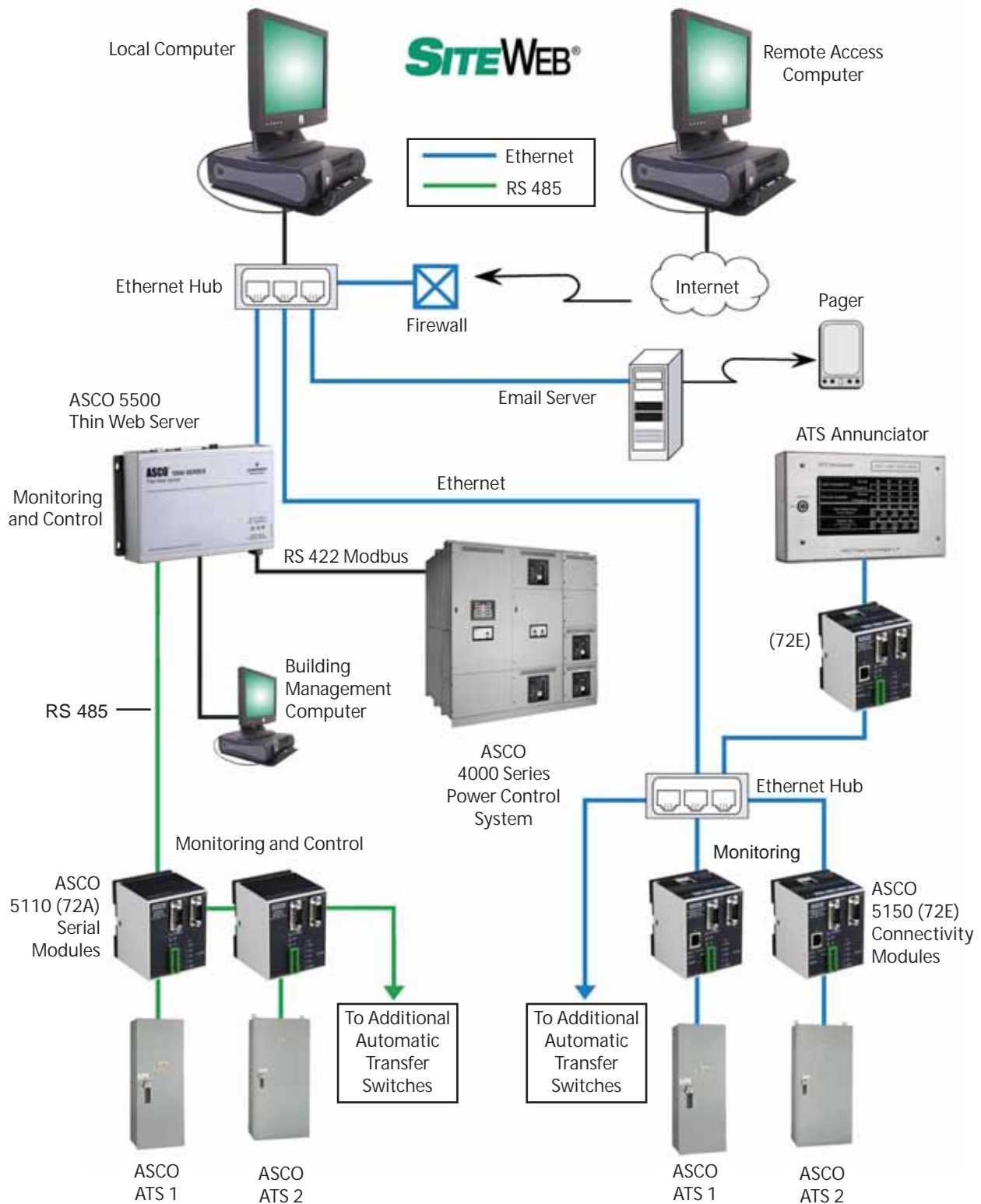

SiteWeb® is a client-server application requiring no software to be installed on the client computer. When combined with the ASCO Communication Interface Modules (Acc 72A, Acc 72E), and the ASCO 5500 SERIES Thin Web Server provide the most comprehensive Intranet and Internet communication system for the monitoring and control of power transfer switches and engine generators located in your emergency or standby power distribution system. The *SiteWeb*® communication system allows multiple client access, from local or remote locations, and provides for the monitoring of up to 64 power transfer switches and eight engine generators. In addition, automatic paging is provided for all alarm signals.

PowerQuest® vs. SITEWEB®

ASCO Connectivity Solution Guide Feature	PowerQuest® VPI 32.15	Thin Web Server with SiteWeb®	5150 Connectivity Module
Quantity of Monitored / Controlled Power Transfer Switches per LAN	32	64	1024+
Number of Monitored / Controlled Gensets	4	8	1024+
Control & Monitoring Capability	Yes	Yes	No
Embedded Web Pages	No	Yes	Yes
Ethernet Network Compatible	Yes	Yes	Yes
Monitor Multiple Protocols & Baud Rates (ASCO I, ASCO II, Modbus)	No	No	Yes
Monitor Multiple Sites	Dial-Up	Internet	Intranet
Multiple Client Access	No	Up to 8	Up to 8
Client Software Required	Yes	Internet Explorer	Internet Explorer
Monitors Dissimilar ASCO Controllers on Common LAN	No	No	Yes
Communicates with ASCO Remote Annunciators	No	No	Yes
Email / Paging Alarms	No	Yes	No
Historical Trending Option Alarms	No	Yes	No



Fig. 19: Serial Module

5110 Serial Module

Cat. No: 5110 Acc. No: 72A

The Serial Module (5110) is used to allow local or remote connectivity with ASCO PowerQuest® or SiteWeb® connectivity products. The module is used to connect SERIES 300 transfer switches to a serial network via an RS-485 interface. The module has two port connectors used for ATS & Stand-alone Power Manager connectivity.

The serial connection is accomplished from a 5-pin terminal header/socket block. The serial network can support up to 32 devices.



Fig. 20: Connectivity Module

5150 Connectivity Module

Cat. No: 5150 Acc. No: 72E

The Connectivity Module (5150) is used to bring several different serial devices that communicate at different baud rates and with different protocols to a common Ethernet medium. The module is used to connect SERIES 300 transfer switches to a standard 10BaseT Ethernet TCP/IP network using standard RJ-45 connectors. The module contains built in JAVA™ applets (program applications for an internet browser) for each monitored device that can load automatically to a standard Web Browser.

The module is designed to communicate with up to 8 clients such as Web Browsers, and PowerQuest® systems simultaneously over the ethernet connection.



Fig. 21: Telephone Interface Module

5120 SERIES Telephone Interface Module

Cat. No: 5120

The ASCO Telephone Interface Module (TIM) allows users to dial directly into their ASCO communications network for monitoring and/or control. The TIM connects to the ASCO communication network via RS-485 and the phone port connects directly into an analog phone jack. Also, the TIM has an RS-232 connector which allows the TIM to be used as the dialing modem.

Supplied with 120 VAC to 18 VDC (nominal) UL approved, class 2 power supply.



Fig. 22: Automatic Transfer Switch Annunciator

Automatic Transfer Switch Annunciator

Cat. No: 214A400

The ASCO ATS Annunciator is a stand alone device capable of providing individual status annunciation for up to four transfer switches. Separate LEDs indicate switch status and position. Separate push buttons individually initiate transfer switch operation and testing. Transfer switch annunciators can also be set up in multiple locations to monitor the same devices, allowing for redundant annunciation of business-critical transfer switches.

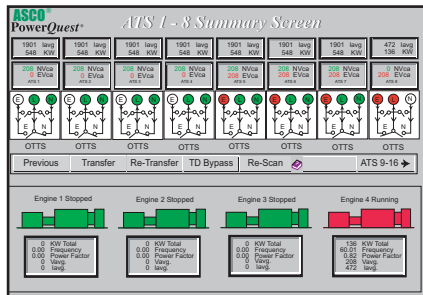

Fig. 23: ASCO PowerQuest® Vpi 32.15

PowerQuest® VPi 32.15

Vpi 32.15 is a PC based monitoring and control system for ASCO devices. The local RS-485 network connects with up to 32 Power Transfer Switches and four Engine Generators. An analog phone connection and ASCO Telephone Interface Module allow for direct dial up, monitoring and control of remote locations. When combined with the ASCO 5110 Serial Module (Acc. 72A), the ASCO 5120 Telephone Interface Module, and the ASCO 5200 SERIES Power Manager, it provides the most economical communications system for monitoring and controlling Power Transfer Switches and Engine Generators.



Fig. 24: Thin Web Server

5500 SERIES Thin Web Server

Cat. No: A5510

The ASCO Thin Web Server allows you to monitor and control transfer switches and engine generators anytime over the Internet or an Intranet from anywhere in the world. It also transmits an e-mail message that an alarm has occurred with one or more of the transfer switches. Plus, this is possible from your home computer or anywhere that has Internet service, using the ASCO Thin Web Server with its embedded SiteWeb® HTML web pages.



Fig. 25: ASCO 5200D SERIES Power Manager

5200 SERIES Power Manager

Cat. No: 5220D

The ASCO 5200 SERIES Power Manager is a microprocessor metering device specifically designed for transfer switch applications to provide real-time measurements of single and three-phase power systems. It uses digital signal processing technology to measure voltage and phase currents, which it uses to calculate real, reactive, and apparent power and bi-directional energy. All measurements can be displayed locally or at a remote PC via PowerQuest® or SiteWeb®. It can also collect data for both normal and emergency positions using auxiliary contact inputs from the transfer switch. Eight digital input and four digital outputs available for customer use. The ASCO 5200 SERIES Power Manager is available with or without a stand alone NEMA 1 enclosure.



GeneratorJoe

4016 Quartz Drive
Santa Rosa, CA 95405
Phone: 707 539-9003
Fax: 707 539-5212
Email: sales@generatorjoe.NET
Web www.generatorjoe.NET

ASCO Power Technologies®



GeneratorJoe

4016 Quartz Drive
Santa Rosa, CA 95405
Phone: 707 539-9003
Fax: 707 539-5212
Email: sales@generatorjoe.NET
Web www.generatorjoe.NET

- ASIA
- AUSTRALIA
- BRAZIL
- CANADA
- GERMANY
- JAPAN
- MEXICO
- SOUTH AFRICA
- SOUTH AMERICA
- UNITED ARAB EMIRATES
- UNITED KINGDOM
- UNITED STATES

Emerson Network Power.

The world leader in business-critical continuity.

- | | | | |
|------------------|------------------------------|----------------------------|---------------------------|
| AC Power Systems | Embedded Power | Power Switching & Controls | Site Monitoring |
| Connectivity | Integrated Cabinet Solutions | Precision Cooling | Surge & Signal Protection |
| DC Power Systems | Outside Plant | Services | |

EmersonNetworkPower.com