

# **OPERATION AND INSTALLATION GUIDE**

**FOR DIESEL FUEL MODELS:  
25-JD THRU 210-JD  
(JOHN DEERE DRIVEN, DIESEL GEN-SETS)  
AND  
250-MT THRU 600-MT  
(MTU DRIVEN, DIESEL GEN-SETS)  
AND  
250-CV THRU 600-CV  
(VOLVO DRIVEN, DIESEL GEN-SETS)**

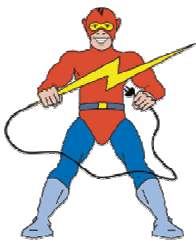

## **GeneratorJoe**

**AUTOMATIC POWER SYSTEMS**

# DIESEL GENERATOR-TABLE OF CONTENTS

	<u>Page</u>
Introduction, General Cautions, Warnings, Danger & Danger Points -----	3-10
Receiving, Un-packing and Installation of your Generator Set -----	10-13
Diesel Generator Dimensional Chart -----	13
Muffler and Generator Installation on Open (No Housing) Gen-Sets-----	14-15
Engine Muffler and Radiator Systems -----	16-17
Diesel Starting, and Battery Requirements -----	17-19
Typical Optional Equipment & Housing Information -----	19-20
Diesel Engine Oil Requirements-----	21
Diesel Engine Oil and Engine Radiator Service-----	22-23
Diesel Generator Considerations-----	23-24
Terminal Connector Torque Tightening Information -----	25
Electrical/Mechanical Formulas That May Be Useful -----	26

See separate Engine, Generator, or Optional Equipment manuals for more specific operating details.

See separate Controller manual for actual operating details.

# PRODUCT SAFETY INFORMATION

## SECTION 1

### **SAFETY RESPONSIBILITY**

**Be sure that you are completely familiar with the safe operation of this equipment. Improper use can cause serious or fatal injury.**

Generator installation and repair procedures require specialized skills. Contact service department for repairs or any questions you may have about the safe installation and operation of this system.

The precaution statements are general guidelines for the safe use and operation of this generator. It is not practical to list all unsafe conditions. Therefore, if you use a procedure that is not recommended or not mentioned in this manual, you must determine if it is safe for the operator and all personnel. If there is any question of safety, please contact dealer before attempting installations or repairs. This generator contains high voltages. Electrical shock can cause serious or fatal injury. Only qualified personnel should attempt the start-up procedure or repair of this generator.

- Only qualified personnel with knowledge of the safe installation, operation, and maintenance of this generator should attempt installation, start-up, operating, or repair procedures.
- Keep all non-qualified personnel at a safe distance from this generator.
- Always stop generator and allow generator cool-down before refueling, restoring oil level, or adding to radiator coolant.
- Always stop generator before making or removing any connections.

### **RESPONSIBILITY**

When your generator is delivered, it becomes the responsibility of the owner and installer to prevent unsafe installation conditions and operation of the generator. Some responsibilities include (but are not limited to) the following:

- It is the responsibility of the owner/operator of this generator to ensure that this generator is correctly installed.
- It is the responsibility of the owner of this generator to ensure that any person operating this generator has access to all manuals and information required for the safe use and operation of this generator.

- It is the responsibility of the owner of this generator to ensure that any person operating this generator has been properly trained.
- It is the responsibility of the owner of this generator to ensure that it is properly maintained at regular service periods.
- It is the responsibility of the owner/operator of this generator to ensure that this installed generator fully complies with all federal, state, and local codes.

### **READ THIS MANUAL THOROUGHLY AND KEEP A COPY AT GENERATOR SITE**

If you do not understand any procedure, precaution or any safety warning statement, or any part of this manual, contact dealer or your nearest generator representative.

### **IMPORTANT SAFETY INSTRUCTIONS** **Precaution Statements Used In This Manual**

There are four classifications of precautionary statements used in this manual. The most critical is a "DANGER" statement, then the "WARNING" statement, followed by "CAUTION", and the least critical is the "NOTICE" statement. The usage of each statement is as follows:

**DANGER:** Indicates a potentially hazardous situation which, if not avoided, could result in personal injury or death.

**WARNING:** Indicates a potentially hazardous situation which, if not avoided, could result in serious personal injury.

**CAUTION:** Indicates a hazard that if not avoided, might result in minor or moderate personal injury or damage to gen-set.

**NOTICE:** Indicates technical or general information.

### **IMPORTANT SAFETY INSTRUCTIONS** **SAVE THESE INSTRUCTIONS**

This manual contains important instructions for the generator that must be followed during installation, operation, and maintenance of the generator, battery (batteries), and fuel components. For ease of reading, the following precautionary statements are summarized in the next 3 pages and are specifically mentioned again in some operation/installation paragraphs, within this manual.

**DANGER:** Be sure that you are completely familiar with the safe operation of this equipment. Improper

use by non-qualified operator can cause serious or fatal injury.

**DANGER:** Disconnect all electrical wires and load devices from generator power outlets before servicing the generator. Electrical shock can cause serious or fatal injury.

**DANGER:** Be sure all wiring complies with the National Electrical Code (NEC), Underwriters Laboratories (UL), and all regional and local codes. Improper wiring may cause a hazardous condition and exposure to electrical hazards can cause serious injury or death.

**DANGER:** Have electrical circuits and wiring installed and checked by licensed electrician or qualified technician. Electrical shock can cause serious or fatal injury.

**DANGER:** Inspect all wiring frequently and replace any damaged, broken, frayed wiring, or wires with damaged insulation immediately. Electrical shock can cause serious or fatal injury.

**DANGER:** Never connect this generator to the electrical system of any building unless a licensed electrician has installed an approved automatic transfer switch. The National Electrical Code (NEC) requires that connection of a generator to any electrical circuit normally powered by means of an electric utility must be connected by means of an approved automatic transfer switch equipment to isolate the electrical circuit from the utility distribution system when the generator is operating. Failure to isolate the electrical circuits by using an automatic transfer switch may result in injury or death to utility power workers due to back-feed of electrical energy onto the utility lines.

**DANGER:** Be sure the system is properly grounded before applying power. Do not apply AC power before you ensure that grounds are connected. Electrical shock can cause serious or fatal injury. NEC requires that the frame, the generator housing, and exposed conductive surfaces (metal parts) be connected to an approved earth ground. Local codes may also require proper grounding of generator systems.

**DANGER:** High voltage may be present whenever engine is running. Electrical shock can cause serious or fatal injury. Never operate electrical equipment while safety screens and guards are removed, or while standing in water, on wet ground or with wet hands, feet or shoes, or while barefoot.

**DANGER:** Make sure protective covers over all rotating parts such as drive shaft, pulley, belt, etc. are in place. Rotating parts can cause extremely dangerous situations because they can catch loose

clothing or extremities and cause serious or fatal injury.

**DANGER:** Do not put hands, feet, tools, clothing, or other objects near rotating parts such as cooling fan, drive shaft, pulley, belt, etc. Rotating parts can snag loose clothing or extremities and cause serious or fatal injury.

**DANGER:** Disconnect the battery's ground terminal before working in the vicinity of the battery or battery wires. Remove all rings, watches, necklaces, or any jewelry before working on batteries. Contact with the battery can result in electrical shock when a tool or other metal object accidentally touches the positive battery terminal or wire. The risk of electric shock is reduced when the battery ground lead is removed during installation and maintenance.

**DANGER:** The positive battery cable is installed and controlled in such a manner that if accidentally cut or sheared, the cable can not short out to the housing doors. DO NOT remove any ground jumper installed on generator set.

**DANGER:** The battery electrolyte is a dilute sulfuric acid that is harmful to the skin and eyes. It is electrically conductive and corrosive. The following precautions are to be followed when working on batteries: Wear protective clothing, safety glasses and gloves; for eye contamination, flush eyes with water and seek medical attention immediately; use an acid neutralizer for spilled electrolyte. Remove all jewelry (watches, rings, necklaces, etc.) and use insulated tools when working with batteries.

**DANGER:** Engine coolant is under pressure and is near boiling point of water when engine is hot. DO NOT open the coolant system until the engine has completely cooled. Hot coolant can cause severe burns and other injuries. When engine is cool (approximately one hour cooling time), coolant level can be checked by slowly removing the turn-lock radiator cap.

**DANGER:** Only a professional experienced technician should install a fuel supply system. All fuels are flammable and can cause fire, explosions, injury, or death. Read and comply with special fuel installations methods within this manual. Comply with all NFPA regulations and local codes for shut-off valves, regulators, fuel line type, connectors, etc.

**DANGER:** Exhaust fumes/gases are extremely dangerous and can cause severe illness or death. Never breath engine exhaust fumes. Only run the engine outdoors where ventilation is plentiful, or inside a non-inhabited room/building having specific exhaust rules. Exhaust gases contain carbon monoxide, a colorless, odorless, and extremely dangerous gas that can cause unconsciousness or

death. Symptoms of carbon monoxide poisoning include: dizziness, nausea, headaches, sleepiness, vomiting, or incoherence. If anyone experiences these symptoms, get out into fresh air immediately. Stop the engine and do not restart the engine until it has been inspected and if necessary repaired or generator may need an increase in cooling air input and hot air output.

**DANGER:** Never operate the generator set indoors in a poorly or non-ventilated area. Exhaust fumes are extremely dangerous to all personnel and livestock that are in a badly ventilated area.

**DANGER:** Before cleaning, inspecting, repairing, or performing any maintenance to the generator set, always be sure the engine has stopped and that all rotating parts have also stopped. After stopping, certain components are still extremely hot, so be careful not to get burned. Before servicing the generator set, **be sure to disconnect the battery terminals to prevent accidental engine rotation or starting.**

**DANGER:** Some parts of this generator rotate during operation. Even though safety screens are installed to protect operator and service personnel from accidental contact, it is wise to know and understand, that rotating parts are dangerous. Never touch any part of generator until it is completely stopped moving, then disconnect positive cable on battery.

**DANGER:** Never operate the engine when the air cleaner is removed. This removal may cause a backfire and serious burns can result.

**DANGER:** Do not smoke within 20 feet of generator during standstill or operation, or within same distance of fuel source. Fuels, and fuel fumes, can cause fire, explosions, injury, or death.

**DANGER:** Check all fuel supply piping and their connection monthly for leaks. All fuels are flammable and can cause fire, explosions, injury, or death.

**DANGER:** Incorrect installation of this generator set and its fuel system could result in property damage, injury, or death. Connection of the generator to its fuel source must be done by a qualified professional technician or contractor.

**DANGER:** Never allow the un-informed, children, or animals to be in the area where the generator is running. The generator, or the equipment being powered by the generator, may cause illness, injury, or death.

**DANGER:** Do not dispose of battery or batteries in a fire, or mutilate the battery. The battery is capable of exploding. If the battery explodes, electrolyte solution will be released in all directions. Battery

electrolyte solution is caustic and can cause severe burns and blindness. If electrolyte contacts skin or eyes, immediately flush the area with water and seek medical attention quickly.

**WARNING:** Never permit anyone to operate the generator without proper instructions. Be sure to keep a copy of this manual with the generator so that all users can read these precautions and be properly informed of its safe operation.

**WARNING:** Never operate this generator in a manner other than as described in this manual. Operation in any manner not described in this manual should be considered unsafe and should not be attempted. Never start the engine unless you first have verified that the installation and operation of the generator is as described in this manual.

**WARNING:** When operating this generator keep alert. Never operate machinery when physically or mentally fatigued, or while under the influence of alcohol, drugs, or medication.

**WARNING:** Always wear safety glasses and hearing protection when working near the running generator.

**WARNING:** Never operate the generator unless all guards, covers, shields, and other safety items are properly installed.

**WARNING:** Positive and negative battery cables should be insulated from "touch" (use battery connection boots) on all battery connections.

**WARNING:** Installation and servicing of batteries is to be performed or supervised by personnel knowledgeable of batteries and the required precautions. Keep unauthorized personnel away from batteries.

**WARNING:** Keep a fire extinguisher near the generator while generator is in use, and know how to use the extinguisher. Use an extinguisher rated "ABC" by the National Fire Protection Association.

**WARNING:** Installation and repair procedures requires specialized skills with electrical generating equipment. Any person that installs or performs repairs must have these specialized skills to ensure that the generator set is safe to operate. Contact dealer for installation or repairs, when questions arise.

**WARNING:** Never connect or disconnect loads during operation. Always connect load circuits before starting the engine.

**WARNING:** Circuit overload protection (automatic circuit breakers) must be provided in accordance with the National Electrical Code and local regulations.

**WARNING:** Parts of this generator are extremely hot during and after operation. To prevent severe burns, do not touch any part of the generator until you have first determined it has cooled down to a safe point to touch.

**WARNING:** Be sure that you understand how to stop the engine quickly in case of an emergency situation. Become familiar with the engine controller and safety systems provided with this generator set.

**WARNING:** Engine coolant is under pressure and is near the boiling point of water when engine is hot. Do not open the coolant system (turn cap on engine radiator) until the engine has completely cooled. Hot coolant can cause severe burns and other injuries. When engine is cool, radiator coolant level can be checked.

**WARNING:** Keep outdoor style generator at least five feet away from buildings and other structures.

**WARNING:** An open bottom stationary engine generator set must be installed over noncombustible materials and shall be located such that it prevents combustible materials (leaves, paper, rags, etc.) from accumulating under the generator set.

**WARNING:** Keep generator away from flammable or hazardous material (trash, rags, lubricants, explosives, paints, etc.) and grass or leaf build-up.

**WARNING:** Hot exhaust gasses must never be directed toward anything that may catch fire or explode.

**WARNING:** Unauthorized modification of a generator set may make the unit unsafe for operation. Be sure that the unit is safe before starting the engine. If you are unsure, contact dealer before starting the engine.

**CAUTION:** Do not apply high voltage to wet windings. Do not start the generator when the generator has been saturated with moisture.

**CAUTION:** Never install a generator with prevailing high winds, towards the engine radiator (heated air discharge) or the muffler rain cap (wind keeping rain cap open after shut down). Inspect rain cap often to ensure rain cap closure upon shutdown.

**CAUTION:** Avoid installing the generator set beside heat generating equipment, water or steam discharge systems, or in the vicinity of corrosive substances or vapors, metal particles, and dust. Heat can cause engine problems to develop and unwanted substances can cause rust or generator failure over time. Steam or water penetration will destroy generator windings.

**CAUTION:** Do not operate generator in tropical ambient conditions without a special protected insulating varnish on generator windings and insulation system. Copper windings absorb moisture and soon cause a generator malfunction.

**CAUTION:** Never operate the engine without a muffler, or with a rusted muffler. Dangerous exhaust components can present a fire hazard, cause excessive exhaust gases and cause damage to engine. Inspect muffler periodically and replace if necessary.

**CAUTION:** Use only original equipment or authorized replacement parts.

**CAUTION:** Engine speed is factory set to produce the correct voltage and output frequency. Do not change the engine speed, as damage will occur.

**NOTICE:** When moving the generator, use reasonable caution. Be careful where you place fingers and toes to prevent injury "Pinch Points". Never try to lift a heavy generator without a hoist or lift means because bodily injury may result.

**NOTICE:** This generator must not be used on or near any forest covered, brush covered, or grass covered land unless the engine's exhaust system is equipped with a USDA spark arrestor screen. The spark arrestor screen must be maintained in effective working order by the operator.

## SAVE THESE INSTRUCTIONS

**THIS MANUAL CONTAINS IMPORTANT INSTRUCTIONS THAT MUST BE FOLLOWED DURING INSTALLATION, OPERATION, AND MAINTENANCE OF THIS GENERATOR SET AND ALL ASSOCIATED EQUIPMENT.**

Thoroughly read this operators manual before installing, operating, or servicing your generator set. Safe operation and best performance can be achieved only when this generator is operated and maintained properly.

## INTRODUCTION

Thank you for your purchase of this **SENTRY** automatic start/stop standby generator set. This generator set is intended for use as an alternative source of electric power to operate normally required electric loads, during a utility power failure.

This generator set has an all weather protected metal enclosure, **MADE EXCLUSIVELY FOR OUTDOOR INSTALLATION**, and will operate on its specific fuel.

Manufacturer has made every effort to present a modern, safe generator set that will give you a safe, clean supply of an alternative electric source. However, because each installation is different, it is impossible for this manual and manufacturer to know and advise against all possible hazards. The listings of dangers, warnings, cautions, and notices in this manual and on tags and decals affixed to the generator set, are therefore, **NOT ALL INCLUSIVE**. If a certain procedure, work method, test method, or operating procedure is used, and is not recommended by dealer, the person or company responsible for the generator modification, must assume all responsibility for safety and correct operation for the operator, service technician, and all others within generator area.

**READ YOUR GENERATOR SET MANUAL, PLUS SEPARATE ENGINE OPERATORS MANUAL AND AUTOMATIC TRANSFER SWITCH MANUAL CAREFULLY. KNOW YOUR EQUIPMENT BEFORE YOU USE IT. CONSIDER ANY POSSIBLE, POTENTIAL HAZARDS, BEFORE OPERATING YOUR GENERATOR SET.**

**CAUTION:** Only current licensed electrical and plumbing contractors should install your standby generator. All phase of installation must comply with all applicable local and national codes, industry standards, and regulations.

**THE WARRANTY IS AUTOMATICALLY NULL AND VOID WITHOUT THE USE OF LICENSED ELECTRICIANS AND PLUMBERS, AND SO NOTED ON THE REGISTRATION FORM THAT IS TO BE RETURNED TO DEALER.**

## IMPORTANT SAFETY RULES

The safety alert symbol  is used as a signal for possible danger, caution warning, or general hazard.

**DANGER:** Indicating a hazard that, if not avoided, will result in death or serious injury.

**WARNING:** Indicating a hazard that, if not avoided, could result in a serious injury.

**CAUTION:** Indicating a hazard that, if not avoided, might result in minor or moderate injury.

**NOTICE:** Indicating a hazard that, if not avoided, could result in general damage.

Read and understand the above listed safety alert symbols, plus the following symbols that are used through out this manual.

## A LIST OF HAZARD SYMBOLS AND THEIR MEANINGS

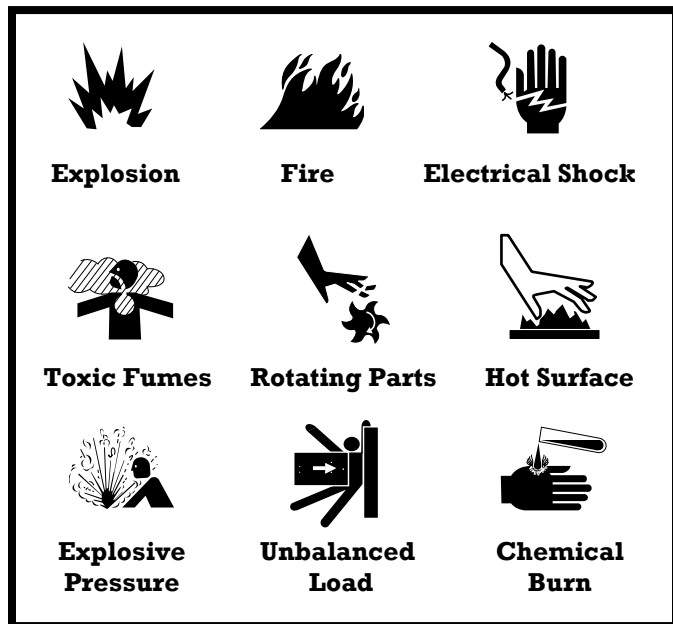





Figure 1



### WARNING



The engine exhaust from this product contains chemicals known to the State of California to cause cancer, birth defects, or other reproductive harm.



### WARNING



California Proposition 65 warning battery posts, terminals, and related equipment are known to the State of California to cause cancer, birth defects, and other reproductive harm.

## NOTICE

- For all safety reasons to the equipment, manufacturer recommends installation, start-up and service be performed by experienced personnel.
- Sufficient, un-obstructed flow of cooling air is critical for correct generator operation.
- The generator must be installed outdoors, away from an over-hang roof where ice and snow could avalanche onto generator and away from sprinklers that could throw water up into cooling vents of generator.
- Electric load applied to generator should be no more than 75% of generator maximum rating to avoid constant maximum generator load use.

- Generator should not be exposed to excessive and constant moisture, dust, dirt, or corrosive environments.

- If connected loads cause over heating or excessive vibration, an overload condition exists. Remove loads until condition stabilizes.

- Do not sit, step, or load heavy items on generator roof. Added stress can cause breakage.

- Do not start generator with air cleaner, air cleaner cover, or oil dipstick removed, nor with oil drain hose in open drain position.

- Keep a fire extinguisher rated “ABC” close by your generator and be familiar on how to use it. Consult your local fire department, for additional fire prevention ideas.

- Be sure that a positive manual, on/off fuel valve be installed in fuel line feeding generator.

- Do not tamper with engine controls, generator is factory adjusted to supply rated voltage and speed.

- Never operate generator when ambient temperature is over 105° F (40°C), as electrical insulation system may fail.

- Never install generator closer than 10 feet to residence where windows can be opened, vents in an overhung roof, or anywhere engine exhaust could possibly find its way into inhabited dwellings.

- Engine coolant is under pressure and is near boiling point when operating. Do not open coolant system until engine has completely cooled. Doing so, will cause severe coolant burns and other injuries.

- An open bottom stationary gen-set must be installed over a noncombustible material and shall be located that prevention of such materials from accumulating under gen-set.

- Only experienced technician should install a fuel supply system. Always comply with all NFPA regulations and local codes.



- Released battery electrolyte can burn your skin and eyes and is toxic.

- When electrolyte touches skin, wash it off immediately with water and seek medical attention. When electrolyte contacts eyes, flush thoroughly with water and seek medical attention.

- Spilled electrolyte must be washed away with an acid neutral agent. Use a solution of one pound bicarbonate of soda to one gallon of water, and wash down acid effected areas until evidence of acid foaming reaction has ended.

- A battery provides risk of electric shock. Remove watches, rings, or other metal items when working with batteries. Use tools with insulated handles.

- When disconnecting battery cables, always disconnect the battery charger first, the positive battery cable second, and negative battery cable last. When reconnecting cables, always reconnect the positive battery cable first, then negative cable, and reconnect battery charger last, to reduce possible arcing.

- Discharge body static electricity by touching a grounded metal surface on generator before touching battery.

- Do not dispose of batteries in a fire and do not open or mutilate a battery, as the battery is capable of exploding.

- Lead acid batteries present a risk of fire or explosion because they generate hydrogen gas, within. Do not smoke, nor have flame or spark in a battery area.

 **DANGER** 



**ELECTRICAL HAZARDS**

A generator produces dangerous electric voltages and can cause a fatal electric shock and will cause sudden illness, dizziness, and incoherent actions.

- Despite the safe design of this generator, operating it carelessly, neglecting its normal maintenance, or being ill informed of proper operations can cause possible serious injury or death.

- Avoid contact with bare wires, connection points, etc., while generator is running.

- Do not touch any kind of electrical circuit while standing in water, while barefooted, or while hands or feet are wet or moist.

- Never wear any type of jewelry while working on a

 **WARNING** 



**STARTING BATTERY PRECAUTIONS**



Starting batteries are not furnished with your generator set, but they are available through your qualified installing contractor.

The home or commercial standby generator requires a 12 VDC or 24 VDC fully charged battery.



generator. Jewelry will conduct electricity, causing electric shock.

- If generator must be serviced while it is running, stand on a dry, insulated surface from ground to reduce shock hazard. Never service a generator in the rain or snow.
- Do not allow unqualified or ill-experienced persons to operate or service generator.
- Remain alert at all times. Never work on a generator when you are physically or mentally fatigued.
- This generator is equipped with a ground terminal. Always complete the grounding path from generator to an external grounding source to prevent possible electric shock.
- In case of electric shock, shut the generator down at once. If this cannot be done, free the victim from source of live electric power. **AVOID ANY DIRECT CONTACT WITH VICTIM OR THE LIVE ELECTRIC POWER.** Use a dry piece of wood, a dry rope, or any other such non-conductive item, to free the victim from source of power. If victim is semi or totally unconscious, apply CPR (cardio-pulmonary resuscitation) and call for medical help immediately.
- Inspect all wiring frequently and replace any damaged, broken, or frayed wiring with damaged insulation. Electric shock can cause serious or fatal injuries.

 **DANGER** 



**CARBON MONOXIDE POISON**

A running engine produces a poisonous gas from its muffler exhaust pipe. This is an odorless, invisible, and colorless poison that cannot easily be detected. Breathing carbon monoxide will cause fatigue, headache, dizziness, vomiting, fainting, and in prolong conditions, even death.

- Operate generator only outdoors, where adequate ventilation is available. Avoid generator installations under decks, inside garages or carports, in basement, along side home exterior less than 10 feet of home vent, roof overhang vent, a window that can be opened, or other such home invasion points. Use same precautions when installing generator at property line, close to a neighbor's home, or any buildings that house animals.

 **WARNING** 



**POTENTIAL BURN OR FIRE CONDITIONS**



Contact with exhaust muffler and exhaust pipe can result in serious burns.

Exhaust heat may ignite combustibles such as leaves or other such debris that is allowed to accumulate around base or interior of generator where exhaust exits.

- Do not touch hot exhaust or engine parts, and avoid hot exhaust gases.
- Keep at least a three foot clearance on all sides of generator, for normal service work.
- Do not install generator any closer than ten feet from any combustibles or buildings with walls having less than one hour, fire rating.
- Code of Federal Regulation (CFR), Title 36, states that generators must have a spark arrestor attached to muffler outlet pipe, to eliminate sparks from engine operation. USDA Forest Service standard #5100-C requires spark arrestor protection when generator is operated within federal parks and forests.
- Generator installation must always comply with local codes, standards, laws, and regulations. Check with your local fire department to learn of these precautions. Keep a fire extinguisher (rated "ABC" by NFPA as appropriate use on generator fires) nearby, at all times. Keep the extinguisher properly charged and become familiar with its use.
- Install fuel system in accordance to NFPA 37 and other applicable fuel codes.
- Do not operate gen-set if fuel odor is present or if other explosive conditions exist.
- No fuel or oil leakage is allowed.

 **DANGER** 



**FIRE OR EXPLOSION CONDITIONS**



All fuels are extremely explosive. Make sure the fuel supply system is installed in compliance with local and state fuel codes and regulations. Fuel leaks when ignited, can cause fire and explosion, resulting in harm or possible death.

- Before initial generator start-up, all fuel system lines must be purged and leak tested according to applicable codes by experienced service personnel. No fuel leaks are permitted.
- Do not smoke or allow open flame near generator while servicing fuel system or battery. Lead acid battery will emit a highly explosive hydrogen gas that

can be ignited. Leaks in fuel system can be ignited. Both are conditions that can cause fire and/or explosion, leading to possible death.

- Do not operate generator if smell of fuel is detected.
- Wipe up any oil spills immediately. Remove any debris that has accumulated inside or around generator base and housing.
- Always maintain a scheduled inspection of entire fuel system and starting battery, looking for leaks or other negative conditions.

 **CAUTION** 

Following is a list of potential events that might result in minor or moderate injury or damage to the generator.

- Never operate generator with oil dipstick partially seated or completely missing.
- Never operate generator without air cleaner and cover in place.
- Always check oil drain hose or radiator drain hose for leaks.
- Generator operating speeds over or under 1800 RPM increase risk of operator injury and engine damage.
- Never insert any objects through generator cooling slots.
- The control panel and wiring access area doors must be installed at time of operation.
- If connected electrical items overheat, disconnect them immediately.
- Immediately shut down generator if it loses electrical output, shows sparks, smokes, emits flames, vibrates, or shows any other abnormal operation.
- Do not modify generator design.
- Do not modify carburetion system, as it is factory set for C.A.R.B./EPA emissions certification.

This concludes the limited hazard listing. However, we cannot possibly anticipate every possible hazard. Therefore, the warnings in this manual, plus the warning tags and decals attached to the generator are not all inclusive. If the generator operator has a different operating method, other than described in this manual, then operator becomes responsible to

make sure that different procedure, work method, or operating method is totally safe, against harm and hazards to operators, buildings or environments.

## UNPACKING AND INSPECTION

After receiving the generator, note that it is mounted on a heavy wood skid base and protected by clear plastic wrap. While the transportation carrier is still present, note the condition of skid and generator set. If damage occurs, make a note of damage on carrier's freight bill and have truck driver sign his name on the freight bill, under "Consignor's Memo of Loss or Damage".

If shipping container is used for shipping protection and it shows damage of any kind, and time does not permit container removal for actual generator inspection, while transportation carrier is still available, be sure to:

- Make note of container damage "with possible interior product damage" on carrier's freight bill.
- Have truck driver sign his name on freight bill under "Consignor's Memo of Loss or Damage".

This action will help prove your case against shipper. Always save shipping materials in the event that gen-set must be sent back to factory due to need of extensive repairs.

If damage is noticed after carrier leaves, contact the carrier for "concealed damage" form. **NOTE:** Missing or damaged parts on generator, is not a warranty claim.

## GENERATOR CONTENTS

The generator set is supplied with the following components:

- Generator system will be supplied in (3) different forms: An "Open" (no enclosure) gen-set, a gen-set with standard weather/sound enclosure, or a gen-set with Super-Silent weather/sound enclosure having special silencing foam and "critical" grade muffler.
- Residential muffler system is standard equipment for quiet operation. An upgrade to "critical" or "hospital" grade is available and may be installed on gen-set, as an option. **NOTE:** Any style muffler for any "open" (no weather enclosure) may be chosen and shipped loose, for installation at job-site, by others.
- Heavy duty steel skid base with (4) lifting holes having plastic knock-out cover plugs.
- Two universal locking keys that fit all door locks.

- Starting battery is not included. See page 17 for battery supply information.
- All gen-sets have the required vibration isolators between generator and steel mounting skid base. No further vibration isolation is required.
- Fuel input and return lines are supplied for fuel connections where U.L. double wall tank options are selected.
- One owner/operator panel.

**NOTE:** All accessory items will be pre-mounted and wired to generator. If separate automatic transfer switch (ATS) is ordered, it is shipped loose in cardboard shipping box, separate from standby gen-set.

### AUTOMATIC TRANSFER SWITCH (ATS)



If this generator set is used to provide temporary electric power to circuits when loss of normal utility power occurs, it is required by National Electric Code, to install an automatic transfer switch (ATS).

The ATS must isolate the standby generator electrical system from the utility electrical distribution system when the standby generator is operating (see NEC 700, 701, and 702). Failure to isolate an electrical system with an approved ATS will result in damage to standby generator and also **can result in severe injury or death to utility power workers who may receive electrical back-feed shock from the standby generator set.**

The automatic transfer switch is an optional selection and can be used with any model generator set. All installation procedures, operating cautions, and warranties are responsibility of the separate manufacturers of the ATS.

### PRE-INSTALLATION PLANNING

The beginning installation requires some thought and planning. The following illustrations are meant to familiarize reader with typical installation circumstances and to plan the best installation possible.

First, Federal, State, and local codes may be a factor. The local fire department can be of help on learning these codes. As with all generators, your generator must be installed in accordance with current NFPA-37 and NFPA-70 standards. Contact your local electrical inspector or city hall to insure you are aware of all codes and regulations.

### GENERATOR LOCATION GUIDELINES

Locate the generator site. It should be as close as possible to any diesel fueling source (such as a day tank), and as close as possible to the electrical distribution panel.

- A) Install self housed generator only in outside area.
- B) Place generator on level cement slab that has provisions for water drainage around perimeter.
- C) Install generator where sump pump output, roof run-off from water, snow, or ice, rain down spots, steam discharge, water sprinklers, or any other such actions will not flood the generators.

### RECEIVING AND INSTALLATION TIPS



A running engine gives off toxic exhaust fumes, which cause headache, fatigue, dizziness, nausea, vomiting, seizures, fainting, or death.

**OPERATE HOUSED GENERATOR ONLY  
OUTDOORS  
OR  
OPEN GEN-SETS IN SPECIAL VENTED,  
UNINHABITED BUILDING**

When you receive your weather/sound housed generator, there are several items that require immediate attention.

- A) If gen-set is shipped open with protective wrap, remove wrap and carefully inspect gen-set for any shipping damage or missing optional equipment, before shipper leaves your premise. Note damage or missing parts on shipper's Bill of Lading.
- B) If gen-set is shipped in wooden crate, and crate appears damaged, note this crate damage on shippers Bill of Lading, indicating product damage may be possible due to crate damage.
- C) If gen-set is to stored for a long period before use, the storage area should conform to published storage temperature and humidity specifications.

When lift or hoist equipment is used, to lift the gen-set be careful not to contact overhead power lines or any other obstacles.

Hoist equipment should have appropriate tires for rough terrain to avoid becoming stuck or overturning. If shipping pallet or wood structure is intact, use a forklift to move gen-set. If shipping material is re-

moved, use (2) steel pipes thru the lift point, to lift gen-set. This mounting location of gen-set is important. It must be installed in an area that is protected from harmful gases, liquids, dust, metallic particles, shock, or vibrations. It should be installed in an outdoor location, so that exhaust fumes are vented to the atmosphere. The factory installed weather and sound protected enclosure is designed to keep out undesirable weather elements.

**WARNING**



Unbalanced Weight  
Improper lifting can cause severe injury or death and equipment damage

Do not use lifting eyes.  
Lift the generator set using lifting bars inserted through the lifting holes on the skid.

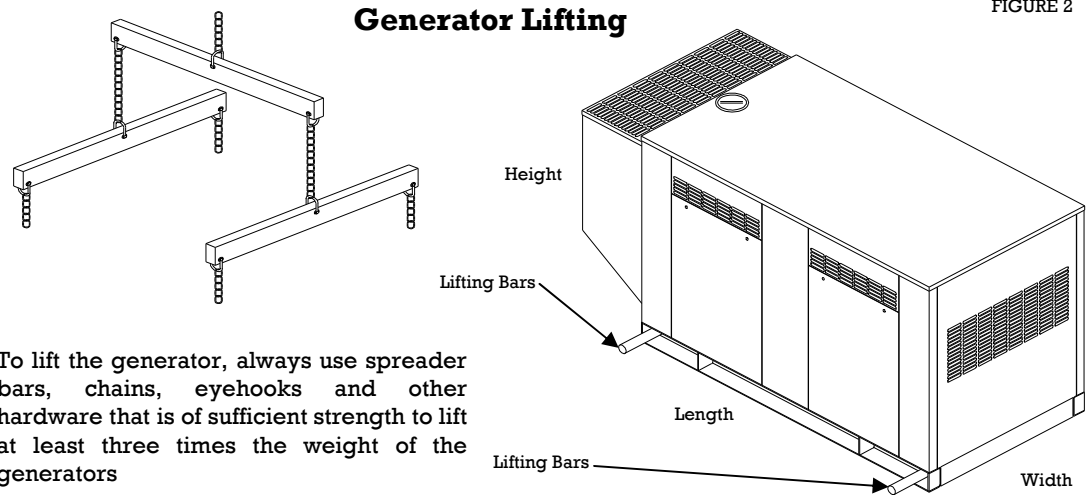

## SUGGESTIONS FOR GENERATOR LOCATIONS

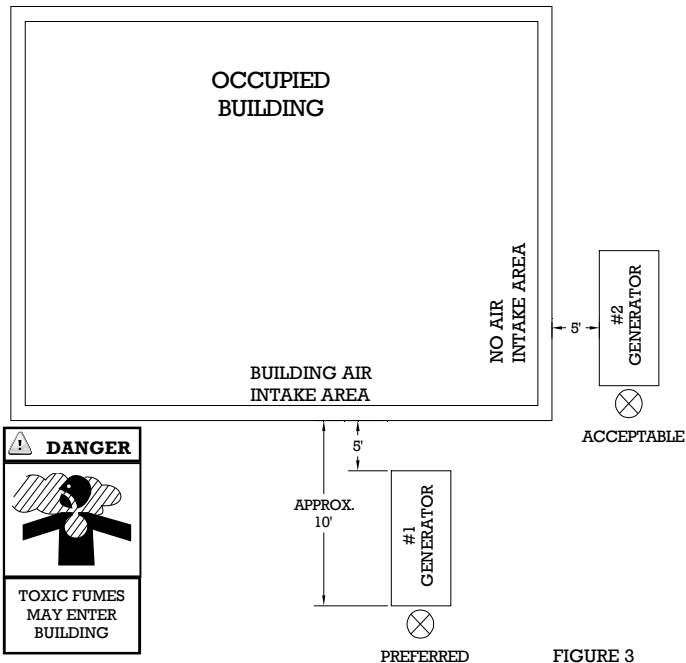

1. Exhaust end ⊗ must always be turned away or parallel with building and minimum 5 feet away.
2. Exhaust end ⊗ is not to be directed towards play areas, patios, under canopies or overhangs, or where people or animals congregate.
3. Do not install generator under deck of house.
4. Furnace and other habited building air intakes should be minimum 20 feet from exhaust end. ⊗
5. Windows and doors on adjacent walls, to be closed at all times, during generator operation.
6. Nearest roof overhang vent or window locations should be minimum 10 feet from exhaust end. ⊗

**WARNING:** An open bottom, stationary gen-set must be installed over a non-combustible material, such as a cement slab, and must be positioned to prevent combustible materials, rain, pooling water, sprinklers from entering into, and accumulating under gen-set.

A) Installation should place gen-set as close as possible to the fuel supply, the transfer switch, and distribution/circuit breaker panel.

B) Service access must be provided to allow generator housing doors to fully open.

C) Installation must prevent water, leaves, grass, snow, etc., from reaching top of generator skid base. Drainage must be provided to keep concrete pad, free from standing water.

D) Always remove snow accumulation on roof when snow depth reaches 4".

E) Maximum ambient operating temperature is 104° F (40°C), for all gen-set sizes.

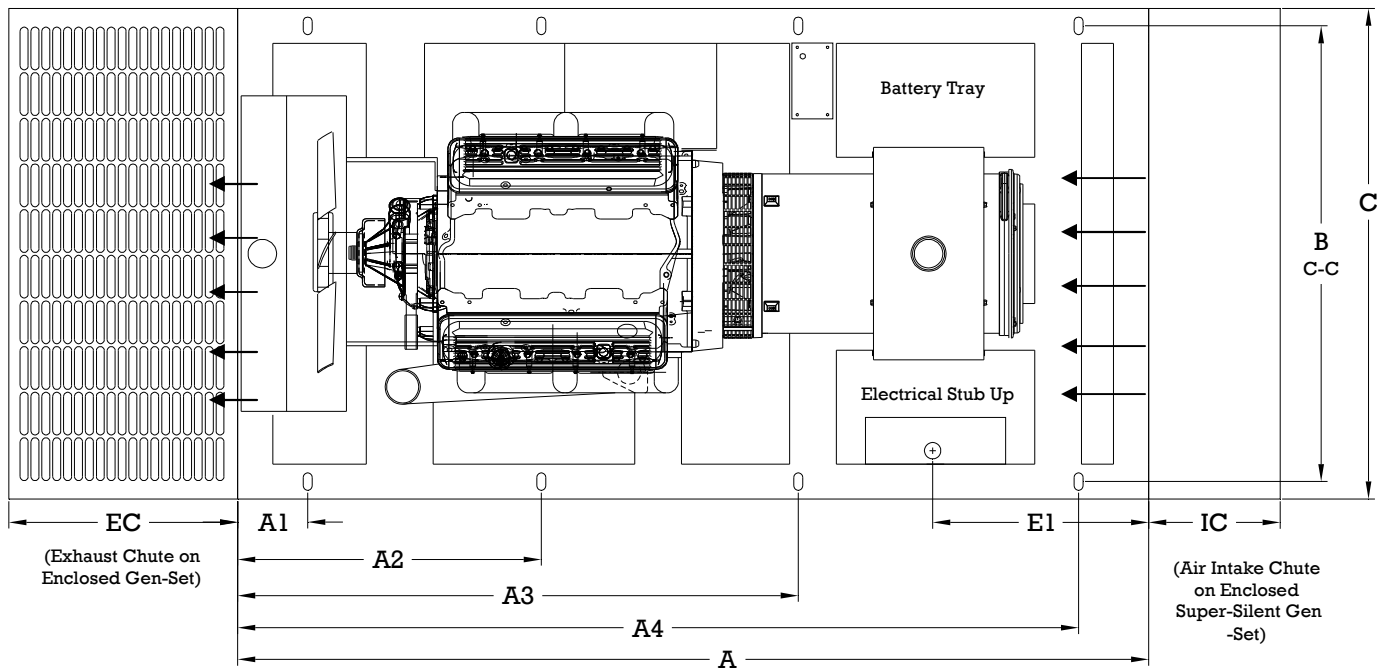

JOHN DEERE DRIVEN, JD GEN-SET MODEL	MTU / VOLVO DRIVEN, MT / CV GEN-SET	A	A1	A2	A3	A4	B	C	E1	EC	IC	HEIGHT
30-JD		68	6	N/A	N/A	62	33	36	18	14	7	47 1/4
60-JD		78	6	N/A	N/A	72	39	42	18	16	8	53
80-JD, 100-JD		98	6	49	N/A	92	45	48	24	24	12	72 1/2
125-JD, 155-JD, 210-JD		110	6	55	N/A	104	45	48	42	24	12	72 1/2
	250-MT, 280-MT, 300-MT	132	8	48	84	124	49	52	23	30	12	80
	350-MT, 400-MT	152	8	53	99	144	69	72	25	34	16	94
	450-MT, 500-MT	152	8	53	99	144	69	72	25	34	16	94
	550-MT, 600-MT	168	9	59	109	159	79	82	28	42	20	100
	250-CV, 300-CV, 350-CV, 400-CV	132	8	48	84	124	49	52	23	30	12	80
	500-CV, 550-CV, 600-CV	152	8	53	99	144	69	72	25	34	16	94

# TYPICAL EMERGENCY GENERATOR INSTALLATION PRACTICES FOR “OPEN” (NON-SELF ENCLOSED) GENERATOR

A standby emergency power systems will give years of dependable service when installed properly. Incorrect installations can cause continuing service problems and may result in harm to humans. It is the responsibility of the owner or operator to know and understand the correct installation methods. It is of particular importance to know safe methods especially, when installing an open generator inside a building. Following is a partial list of recommendations:

- 1) The generator building must not be inhabited by humans or animals.
- 2) The building floor must be cement and capable of supporting generator weight, the running vibration, and any generator associated equipment. If in doubt, have the floor load carrying capacity tested by specialist. A heavy equipment lifting contractor should be consulted for this task.
- 3) The generator engine requires a certain amount of cooling air, which changes with different generator KW sizes. The CFM cooling air requirement, if insufficient, will cause early, automatic shutdown of complete generator set.
- 4) Generator operating noise is high, so quieting devices may be desirable: double walled room, sound deadening materials on wall, etc.
- 5) Building code and safety requirements for open gen-set operation within a building are important to

know and compliance to the codes, are essential: National Electric Code, Articles: 230, 250, 245, 517, and 700.

National Fire Protection Association (NFPA)

- #37—Stationary Combustion Engines and Gas Turbines.
- #99—Essential Electrical Systems for Health Care Facilities.
- #101—Life Safety Code Number Systems.
- #110—1985 Emergency and Standby Power Systems.

Local applicable codes (consult local building inspector or fire department).

6) Generator room size: Room should be dedicated for only generator use, not for miscellaneous storage, work area, etc.

7) Specialized controls, transfer switches, and other generator required equipment may be installed in generator room, depending on local codes.

A drawing showing a typical indoor generator installation is shown at bottom of page.

**MUFFLERS:** There are (4) types of mufflers: Industrial, Residential, Critical, and Hospital grade. Manufacturer does not furnish the muffler as standard equipment due to varying demand for the different grades and type of required mounting of each application.

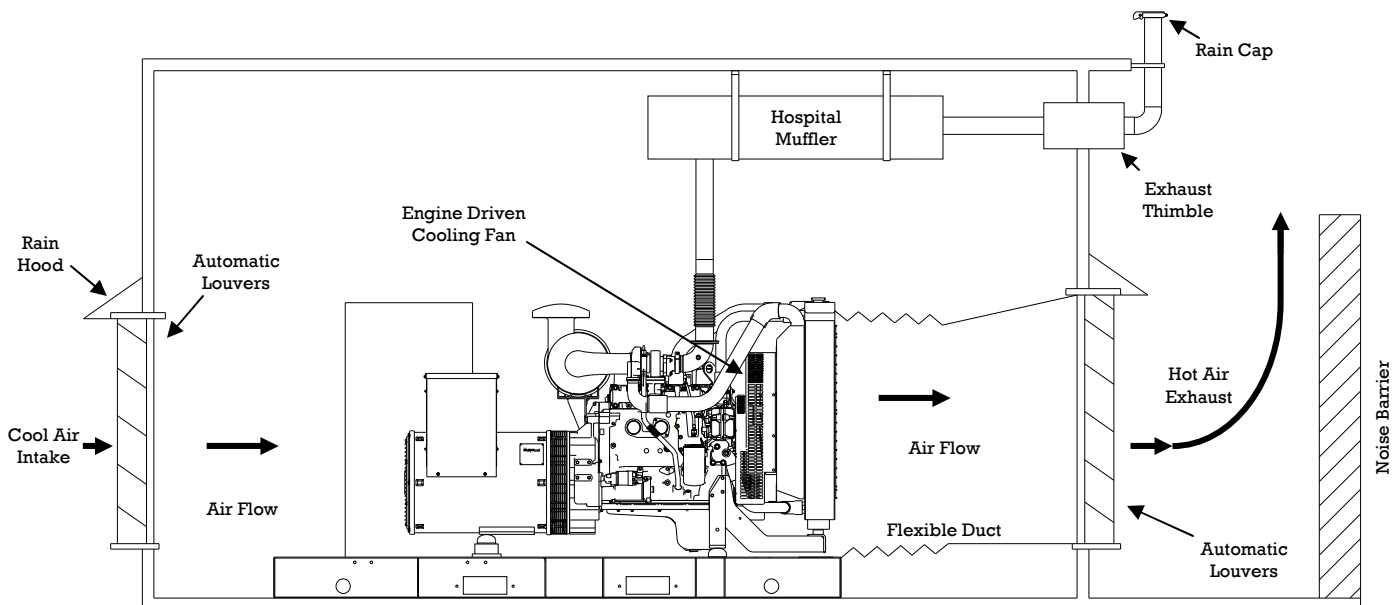

FIGURE 5

It is, however, available as an option purchase. Manufacturer does not offer the "Industrial" grade muffler as it is very loud and is seldom satisfactory to the end user. Muffler selections are: Residential grade (reasonable quietness), "Critical" grade (very quiet) or "Hospital" grade for ultimate silencing. **NOTE:** The gen-set drawings on page 14 shows a horizontal Hospital grade muffler. Residential or Critical mufflers are mounted in a vertical position, directly on the engine exhaust pipe, and exhaust flex pipe mounted on muffler output. Consult factory for special muffler mounting systems using catalytic converters on EPA Certified exhaust emissions for KW sizes 80, 100, 125, and 150. **CAUTION:** Outside vertical exhaust pipes must use a rain cap; exhaust pipe diameter size will increase as length of run increases; flexible piping must be used at generator exhaust beginning; exhaust outlets must be minimum 20 feet from building air intakes or located towards prevailing wind directions; exhaust pipe sleeves or thimbles must be used when exhaust pipe must pass through a wall or partition.

**DANGER**

**ENGINE EXHAUST FUMES ARE EXTREMELY DANGEROUS AND CAN CAUSE SEVERE ILLNESS OR DEATH, IF BREATHED IN.**

Never breath engine exhaust fumes produced by a running generator set. Engine exhaust gases produce a colorless, odorless, carbon monoxide poison gas that can cause dizziness, nausea, headaches, or vomiting. If this happens, get into a fresh air environment quickly. Have someone with safety breathing equipment stop the engine and inspect the entire exhaust system for leaks or improper installation.

**GUIDELINES FOR A SAFE EXHAUST SYSTEM**

- A) Do not allow engine exhaust gases to re-circulate into engine's cooling air input.
- B) Use an exhaust pipe rain cap on vertical pipe ending. Rain getting into exhaust pipe system will cause eventual corrosion and damage to the entire exhaust system.
- C) The remote muffler must be mounted as close to the engine as possible, or it will "carbon up" if its operating temperature is too low.
- D) If installation calls for a Cowl, Residential, or Critical grade muffler, it will be factory mounted directly on the engine exhaust manifold pipe, along with a short 6" pipe as it is compact and light weight. Then install a 12" to 15" exhaust pipe on muffler exhaust end, then install a 12" to 15" flexible exhaust

Pipe, which both is ordered as optional equipment. This short pipe run between muffler and flexible pipe allows the exhaust gases to cool and extend the life of the flexible pipe. **NOTE: Flexible exhaust pipe must be stainless steel.**

E) Water/condensation is a byproduct of engine combustion and is present in exhaust pipe installations. This water should be kept away from draining back into the engine. This can be done by slightly slanting the horizontal exhaust pipe section downward. A water trap consisting of a pipe tee and drain cock should also be provided. See following suggested diagrams.

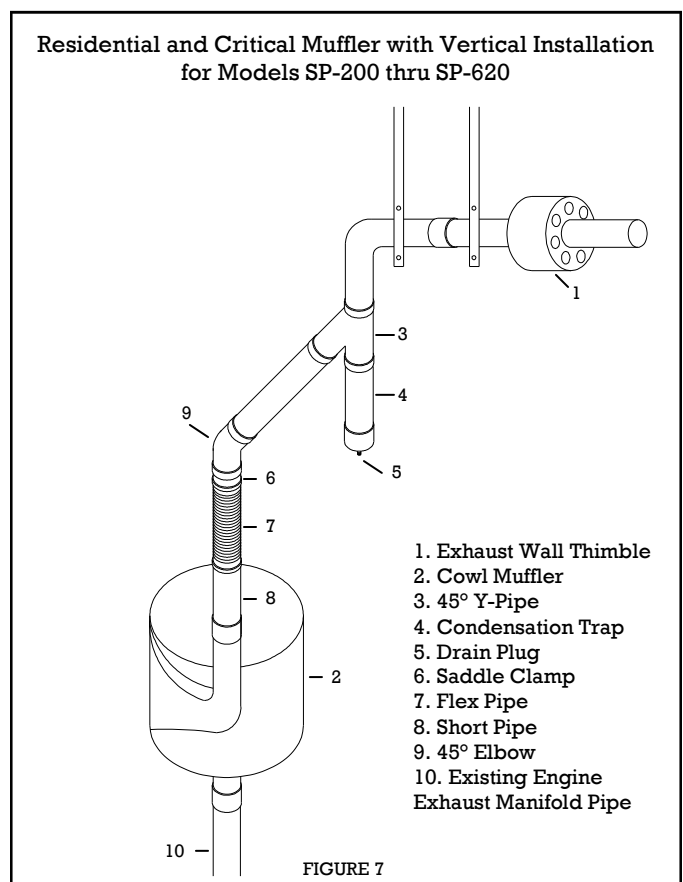
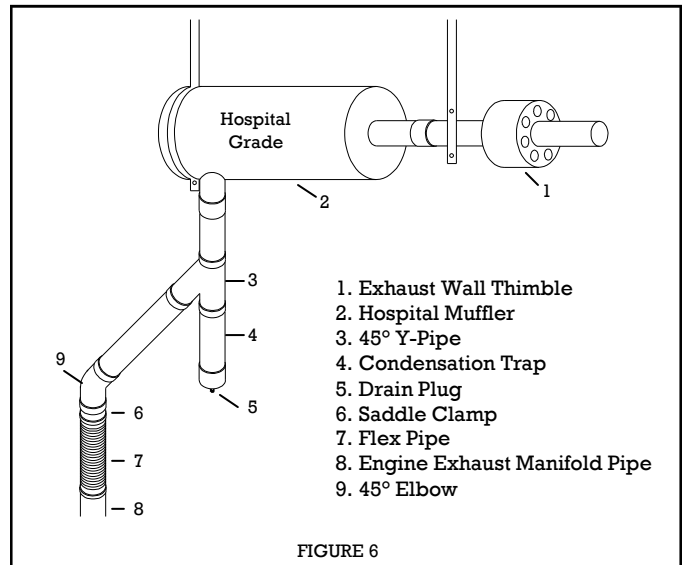

F) The exhaust piping system is subject to engine vibration, so it must be solidly installed to reduce potential for pipe cracks or breakage.

G) It is very important to discharge exhaust gasses away from the engine and out of the generator building. If these gasses remain in the engine cylinders, poor engine performance and eventual engine damage may result. This condition usually results from excessive back-pressure, which can result from:

- 1) Exhaust pipe diameter is too small or exhaust system is too long.
- 2) Excessive amount of bends in exhaust pipe run.
- 3) Obstructions (old birds nest, bees, insects, etc.) in the exhaust system.

All three items are examples that will cause back pressure that **MUST NOT EXCEED 20"/WATER COLUMN**.

### MUFFLER MOUNTING TO GENERATOR

GENERATOR MODEL					
JD / VOLVO DRIVEN	MTU DRIVEN	PIPE SIZE	COWL MODEL	MUFFLER DESCRIPTION	NET WEIGHT LBS.
25-JD 30-JD		2"	TXS-2"	CRITICAL GRADE	19
42-JD 52-JD 60-JD		2 ½"	TXS-2 ½"	CRITICAL GRADE	32
80-JD 100-JD		3"	TXS-3"	CRITICAL GRADE	52
125-JD 155-JD 180-JD 210-JD		3 ½"	TXS-3 ½"	CRITICAL GRADE	63
250-CV	250-MT 280-MT 300-MT	5"	TXS-5"	CRITICAL GRADE	98
300-CV 350-CV 400-CV	350-MT 400-MT	6"	TXS-6"	CRITICAL GRADE	137
	450-MT 500-MT	(2) 4"	TXS-4"	CRITICAL GRADE	162
	550-MT 600-MT	(2) 5"	TXS-5"	CRITICAL GRADE	196
500-CV 550-CV 600-CV		8"	TXS-8"	CRITICAL GRADE	227

Note: Models SPMD-4500 thru SPMD-6000 have a dual muffler system, where (2) silencers are used, one for each turbo exhaust manifold.

Mufflers are shipped loose on all "Open" (no enclosure) generator sets. Mufflers with weight up to 52 pounds can be attached directly to the engine exhaust manifold pipe (See drawing on page 15).

Mufflers more than 52 pounds are too heavy for mounting directly to manifold pipe. These heavier muffler will require separate support structure. The flexible exhaust pipe can be mounted to the engine manifold pipe with additional piping to the ceiling (roof) structure, where muffler can be suspended.

### COOLING THE GENERATOR

Today's engines run on the borderline of over heating, with in-cylinder temperatures close to 2000°. Generator uses a 50/50 mix of glycol/di-ionized water. When we know generator destination is in colder climates such as Northern USA, Canada, or Alaska, a 60/40 mix is used. When replacing coolant in radiator **DO NOT USE** a 50% glycol and 50% tap water. Tap water contains **minerals**, dissolved oxygen, and chlorine, which will cause scaling and corrosion in the engine. Always use a mixture of glycol and de-ionized water or distilled water, never use tap water. Radiators of today's design are extremely fragile and light weight, containing smaller cooling tubes and more cooling fins, so it has become easier to clog radiators with corrosive coolants. Generator, the radiator manufacturer, and engine block manufacture will decline warranty on clogged radiator and engine block problems when it is known that tap water is used rather than distilled water.

### RADIATOR COOLANT CAPACITY (INCLUDING ENGINE BLOCK)

GENERATOR MODEL				
JD DRIVEN	MTU DRIVEN	VOLVO DRIVEN	QUARTS	LITERS
30-JD			9.16	8.6
60-JD			13.0	12.2
80-JD / 100-JD 125-JD / 155-JD 210-JD			37.0	35.0
	250-MT 280-MT 300-MT		67.0	63.4
	350-MT 400-MT		71.7	67.9
	450-MT 500-MT		104.8	99.3
	550-MT 600-MT		112.4	106.0
		250-CV 300-CV 350-CV 400-CV	38.0	35.9
		500-CV 550-CV 600-CV	50.7	48.0

When coolant system is drained and fresh coolant is added, it's best to use a hydrometer for testing the value of antifreeze mixture. A correct 50/50 mix allows freeze protection to -34° F and boil-over protection to 265° F.

### COOLING THE GENERATOR AND ENGINE THAT IS MOUNTED IN A GENERATOR ROOM

Whenever an open (no housing) generator set is installed inside a room, in a building the radiator should be ducted outside the room. See Figure 5, page 14.

The most common method of generator set cooling, is that of a generator mounted radiator. The major components are:



- A) Engine driven blower fan.
- B) Circulating coolant pump
- C) Cooling radiator.
- D) Thermostat.

The blower fan pulls cooling air across the radiator coils. The coolant pump circulates coolant through the engine until it reaches operating temperature. The engine thermostat open and allows coolant to circulate into the radiator core. Thermostat can also close, restricting the coolant flow, as necessary to prevent over cooling. The engine fan blows air, from the engine side, through the fins of the radiator.

When a generator set is installed inside a building room, the radiator air discharge should be ducted outside the building, into the atmosphere. A typical installation is shown on page 14, Figure 5.

Install a set of louvers, 1½ times the size of engine radiator perimeter. Galvanized metal duct must fit tightly around louver perimeter and taper down to be the same size as radiator perimeter, and end at least 24"-30" from radiator. The connection from engine radiator to duct work (12" space) should be heavy canvas, silicone material, or other such flexible material, to prevent noise and vibration transmission. Sheet metal duct work should be self supporting, firmly attached to the hot air discharge louvers.

The cool air inlet opening, should be a second set of louvers that is (2) times the size of radiator perimeter. Over-sizing both air inlet and air outlet, allows for fine screens across the entire louver area to keep birds or flying insects, from entering generator room.

The ideal assembly is to install motorized louvers, so that when generator is started, the louver motors are energized by generator power, and become fully open. Like wise, when generator shuts down, louvers automatically close.

Rain hoods should be installed over top of each louver, mounted on outside wall, so that rain won't enter into open louvers.

### TESTING THE VENTILATION SYSTEM FOR MAXIMUM PROTECTION

Place a thermometer as close as possible to the cool air input (engine cooling fan) of the generator set blower housing. Don't allow thermometer to touch any metal surface. Place a second thermometer outside the building in the hot air discharge, at point of louvers. Be sure not to allow this thermometer to be in direct sunlight or any other heat sources. Run the generator at maximum load for about 1 hour. The temperature difference between the two thermometers, should be no more than 20° F.

## STARTING BATTERY

All generator models have a fixed position for installer furnished, 12 or 24 VDC starting battery. A corrosion free battery tray is furnished with woven hold down strap. Positive and Negative battery cables are installed and ready for connection to installed battery. While installing the battery, notice the Positive battery cable is tightly secured, so that it can't move beyond normal distance from Positive battery post. **DO NOT REMOVE THIS CABLE RESTRAINT.** This is a requirement of UL-2200 and removal of this cable restraint will void UL Certification. Also, battery connection boots for both Positive and Negative cables are furnished and again, required for UL Certification.

Starting batteries are usually sealed lead-acid type, sized to engine manufacturers recommendation for a particular ambient temperature and required cranking time. Recommended engine cranking periods are specified in NFPA-110 and specifies cranking cycles times. Battery sizes per generator model number are on page 18.

Battery is charged by an engine driven, battery charging alternator, while generator set is running. These engine/generator systems have charge rates of 30 to 50 amps or more, depending on size of generator set, and can restore the charge from battery, used in a normal cranking cycle within a short period of time. When generator is in standby position (not running), a very low charge rate from an auxiliary A-C powered battery charger can maintain battery at full charge.

All generators use a 6 or 10 amp, 12 or 24 VDC , 3 stage charger (bulk stage for full amp output while battery voltage rises), absorption stage (regulates battery voltage at constant voltage while current flow to battery decreases), and float stage (supplies charge current at the rate it will be accepted by the battery).

### 12 VDC BATTERY SYSTEM

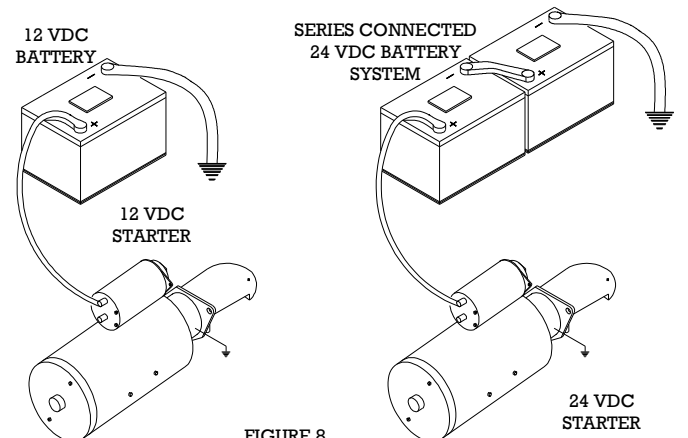

FIGURE 8

## RECOMMENDED BATTERY SIZES

GENERATOR MODEL	BATTERY SIZE
25 KW THRU 30 KW	(1) 12 VDC BATTERY 650 CCA, BCI 24F
42 KW THRU 60 KW	(1) 12 VDC BATTERY 650 CCA, BCI 24F
80 KW THRU 210 KW	(1) 12 VDC BATTERY 710 CCA, BCI 27
250 KW THRU 400 KW (2) 12 VDC BATTERIES CONNECTED SERIES FOR 24 VDC STARTING SYSTEM	(2) 12 VDC BATTERY 710 CCA, BCI 27
450 KW THRU 600 KW (2) 12 VDC BATTERIES CONNECTED SERIES FOR 24 VDC STARTING SYSTEM	(2) 12 VDC BATTERY 1000 CCA, BCI 31
<b>NOTE:</b> BATTERY CCA RATING MAY NEED A 15-20% INCREASE FOR EXTREME COLD TEMPERATURES. BATTERY TRAY WILL FIT MAX DIMENSIONS OF 12"LG X 7"WI	

**Only experienced licensed electricians and authorized service technicians should have access behind closed and locked housing doors.**

## BATTERY SELECTION & INSTALLATION

The 12 VDC battery is not furnished with the standby generator set. The generator can be installed in a wide range of temperatures and climate conditions. As climates get colder, batteries lose their ability to produce required power. Therefore, battery size must be increased. Installer must provide proper battery size, depending on environment.

Climates that reach to a low of 20° F (-6.7° C) can achieve good generator operation with a 12 VDC, 925 CCA battery. Climates that reach below this temperature line should have a 10-20% increase in CCA rating for a 12 VDC battery. See Battery Chart on page 17.

**CAUTION:** All 12 VDC batteries will lose a certain percent of their charge while in storage. It is very important to test the battery voltage before it is installed in generator and taken to jobsite. A fully charged battery must test at 12.5 – 13.0 volts DC. Also, the correct battery must have lug terminals to match lug battery cables, for a bolt-together connection. **When replacing batteries, use the same number and the following type batteries:**  
**Sealed type:lead-acid**

This generator is equipped with a corrosion resistant battery tray, a battery hold down strap and battery cables. Place the selected fully charged battery with full electrolyte in battery tray and secure with battery hold down strap.

Battery cables are factory connected at the generator points (red engine starter motor (positive) cable and black ground (negative) cable). Electrician should connect the red battery cable (from engine starter solenoid point) to battery post shown with "positive", POS, or (+) indicator. Connect the black battery ca

bles (from frame ground) to the battery negative post. **NOTE:** Both positive and negative battery cables have protective "boots" that enclose the cable connections to battery posts. Also, positive battery cable is secured, so that, if cut or disconnected in any way, positive cable won't touch metal door or cable restraint or boots, as both are **required safety measurements.**



## NOTICE

Dielectric grease should be used on battery lugs or posts to help in the prevention of normal corrosion.

Damage will result to generator controls, if battery cables are made in reverse connections.

Inspect, clean, or re-grease battery connections ever 60-90 days.

In cold climate areas, where temperatures normally reach 10° F (-12° C) or colder, an optional battery wrap-around heater, controlled by thermostat, should be used, for increased battery power.

This generator is equipped with an automatic "float type" 3-stage (bulk, absorption, and float) battery charger, energized by utility power, to maintain full battery power while on standby (non-running) condition. **CAUTION:** This charger can not recharge a fully discharged or defective battery.



## DANGER



- Do not dispose of battery in a fire. The battery is capable of exploding and spewing electrolyte in several directions.



- Do not open up a battery. It has electrolyte and is harmful to the skin and eyes, and is toxic.



- Battery electrolyte is electrically conductive and corrosive.



## BATTERIES CAN CAUSE DANGEROUS ELECTRICAL SHOCK

- Contact with battery acid will cause severe burns to the skin and eyes.

A battery can cause an electrical shock. Before working on a battery, follow safe procedures:

- Remove start/stop 20 amp fuse in control circuit.
- Remove all rings, watches, & other metal objects.
- Wear rubber gloves and boots.
- Use tools with insulated handles.
- Do not lay tools or metal objects on top of battery.

- Disconnect the battery charger and positive battery cable before working on battery terminals, or replacing battery. **DANGER:** Never remove protective battery connection boots, or positive battery cord restraint, as dangerous shock conditions may exist.

 **BATTERIES CAN CAUSE DANGEROUS CHEMICAL BURNS**

A battery can cause a chemical burn. Before working on a battery, follow safe procedures:

- Wear full eye protection and protective clothing.
- When battery electrolyte contacts the skin, wash it off immediately with water.
- When battery electrolyte contacts the eyes, flush immediately and repeatedly with water and seek medical help.
- Spilled electrolyte should be washed away with an acid neutralizing product.
- A battery can cause fire or explosion because they emit hydrogen gas.

 **BATTERIES CAN CAUSE FIRE OR EXPLOSION**

- Do not smoke or cause any type of flame within 30 feet from battery.
- Discharge body static electricity from body, by touching a grounded metal surface, before working on battery.

**BEFORE WORKING ON BATTERY:**

- **Always remove 20 amp fuse in control panel.**
- **Always set the controls to off position.**

**TYPICAL OPTIONAL GENERATOR EQUIPMENT**

A) Flexible Fuel Line: This may be a requirement in most local codes. A stainless steel flexible line is installed between gen-set and diesel fuel black ridged pipe. Normal gen-set vibration is not passed on to rigid fuel line. **CAUTION: Flexible line must be installed straight, with no bends allowed.**

B) Engine Coolant Heater: Connected to engine block by flexible tubing. Heater has its own automatic on/off thermostat that operates on 120 VAC, and provides faster cold weather starting.

C) Battery Heater: This is a battery wrap blanket kit with on/off thermostat and operates on 120 VAC, for faster cold weather starting.

D) Emergency Stop Switch: Comes in (3) different styles and operates on 120 VAC. Switch is mounted on exterior of weather housing, or by control panel on “Open” (no housing) generator sets.

E) “Residential”, “Critical” or “Hospital” Grade Mufflers: Are optional choices on “Open” generators. **NOTE:** Housed generators will have a “Residential” grade muffler as standard equipment, with “Critical” or “Hospital” mufflers as optional equipment.

F) Generator Enclosure Lights: For easier servicing at night time.

G) Permanent Magnet Generator (PMG): Allowing superior inductive electric motor starting, and uninterrupted generator excitation power (endures direct short circuit loads for 4-6 seconds) and complies with NFPA-110 requirements.

H) Stainless steel housing upgrades for use in Coastal Regions.

I) Cold Climate: Generator winding, space heaters.

J) Fungus Proofing: For protection of copper windings for coastal areas and the “Tropics”.

K) “Intelligent” Battery Charger: Upgrade, conforming to NFPA-110.

L) “Ultimate” Programmable Controller: Is standard equipment on all standby 4-pole generator sets, and has a vast array of options for almost any application.

M) “Webnet Gateway”: Interface for complete remote access, controlling or monitoring generator from anywhere in the world, with internet service.

**NOTE:** See separate controller manual for operational instructions.

**TYPICAL EMERGENCY GENERATOR INSTALLATION PRACTICES FOR AN ALL WEATHER/SOUND PROTECTED METAL ENCLOSURE**

A standby emergency power system with its own weather protective housing, allows faster and more economical installation than the “Open” generator, requiring a building for its weather and sound protection.

The housing is especially designed for

each KW generator size, paying close design attention to the required amount of cooling air entering the housing, and to ensure adequate hot air discharge is ample, sound deadening is maximum, without degrading normal operation of generator set.

The generator housing is all metal, with air openings and air baffles, strategically located to maximize hot air discharge and minimize vibrations and sound. Sound deadening foam is used thru-out the interior of the metal enclosure.

A particular importance is the interior and exterior housing finish. All housing parts undergo the following process:

- A) There are (5) separate heated washings to insure a clean metal part.
- B) The 6th stage is a complete emersion into a zinc phosphate solution to ensure full corrosion resistance.
- C) Each part is separately E-Coated by complete tank emersion, to ensure complete coverage protection in even the most complicated formed parts.
- D) Final finish is a UL Certified powder coat enamel for outside operation, and a final bake finish, providing a "Best of Class", semi-gloss protection, for years against rust and corrosion.

There are two choices of sound/weather protected housings:

- 1) "Standard" housing with standard interior sound deadening foam and mounted residential grade muffler.
- 2) "Super-Silent" housing with special interior foam having damping material included.
- 3) "Super-Silent" housing also has a "Critical" grade muffler included with a choice of "Hospital" grade muffler as an additional upgrade.
- 4) "Super-Silent" housing also has an additional air chute (much like the engine end air chute) for increased generator

the key into lock and turn counterclockwise. Remove the key and note, the dots are now out of alignment. Re-insert the key, turn clockwise until dots align, and it's in the locked position. All doors are hinged, and once unlocked, will swing open. All keys are universal, used on all housing sizes.

**! DANGER !**

All doors have grounding wire, connecting and grounding door to housing frame. **DO NOT REMOVE** these grounding wires. If it becomes necessary to remove and replace door, be sure to replace grounding wire and to reuse self grounding star washers, to prevent accidental electrical shock, if live circuit wires were to touch housing parts.

**EXHAUST SYSTEM**

The engine end of housed gen-set will have hot exhaust air discharge from engine muffler, mounted within housing for complete generator hot air discharge.

**! WARNING !**

Even though the muffler is safely concealed within hot air engine exhaust chute, the muffler exhaust pipe and its accompanying rain cap, extending straight up from roof, will cause severe burn to the touch. This "Hot Pipe Burn" warning remains in effect for 60 minutes after shut-down of generator set.

**CORROSION TO GENERATOR AND HOUSING**

Depending on the area of generator installation, will depend on the amount of attention given to gen-set cleanliness. Heavy concentration of salt water exposure (USA Coastal Regions, and Tropics), will require frequent washings and a final waxing of generator housing, much like an automobile's special care in these areas. Salt corrosion may enter the generator interior, which may have to be removed by special detergents. Every 3 months, spray the engine governor linkage, springs, and other engine control moving parts with a light spray coverage of WD-40 to help prevent or prolong corrosion destruction.

In severe Coastal or Tropical conditions, it is advised to use aluminum housings, as opposed to steel housings.

**GENERATOR PERFORMANCE**

When matching a generator to a specific application, whether gross intermittent or gross continuous power is used, it is important to derate this power output for the following adverse conditions:

**ACCESS TO HOUSING INTERIOR**

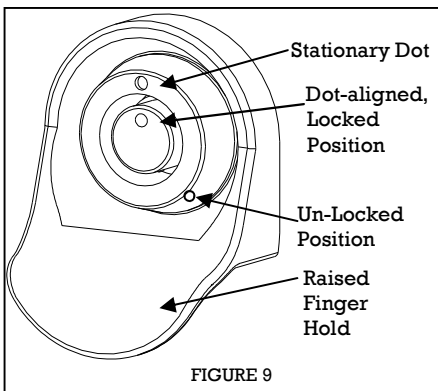

FIGURE 9

end silencing. All generator access doors are locked, and are opened with a common key for all locks. Notice the door lock (in the locked position) has matching dot system in

⚠ Engine power rating after “break-in” is usually within 3% of engine published rating.

⚠ Temperature and altitude directly derate generator power. Derate 3½ % for each 1,000 feet above 326 feet, over sea level. Derate 1% for every 10° F (5.6° C) over 77° F (25° C).

⚠ Generator location is important. If it is located too far from fuel source, fuel line may not deliver adequate fuel. If it is located too far from electric distribution box, the electric power lines may not deliver adequate electric power. Both examples will directly affect generator power. The high voltage access panels should only be

**WARNING**



removed by experienced licensed electricians, repair and service personnel, and installers.



⚠ Electrical shock from mishandled battery.



⚠ Toxic fumes from battery or engine exhaust may be inhaled.



⚠ Hot surfaces may cause severe burns.

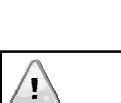

⚠ Explosions from battery or dry fuel fumes being ignited by careless smoking or sparks from mishandled tools.

All hinged or bolted panel contains access

**DANGER**



to A-C and D-C dangerous high voltage electricity. These voltages can cause a fatal electric shock and will cause sudden illness, dizziness, and incoherent actions. Only experienced licensed electricians and authorized service technicians should have access behind closed and locked housing doors.

**FINAL PREPARATIONS BEFORE INITIAL START-UP**

Before checking oil, always set the controller to “OFF” position, and remove 20 amp fuse.

1) Oil Considerations: Check the oil to make sure it’s at the proper level. Remove the oil dipstick, wipe it clean, re-install oil dipstick, then remove it again to check the oil level. See Figure 12.

**RECOMMENDED ENGINE OIL**

GENERATOR MODEL	OIL CAPACITY WITH FILTER QT (L)	GENERATOR MODEL	OIL CAPACITY WITH FILTER QT (L)
30-JD	9.0 (8.5)	250-MT	48.6 (46.0)
60-JD	11.9 (8.2)	280-MT	
		300-MT	
80-JD	14 (13.2)	350-MT	52.9 (50.0)
100-JD	18 (17.0)	400-MT	
125-JD	23 (21.5)	450-MT	64.5 (61.0)
155-JD	26 (24.6)	500-MT	
210-JD	35.3 (33.4)	550-MT	77.2 (73.0)
		600-MT	
250-CV	38.1 (36)	500-CV	44.4 (48)
300-CV		550-CV	
350-CV		600-CV	
400-CV			

SUMMER GRADE OIL: SAE-30 / SAE-40  
WINTER GRADE OIL: SAE-5W-30

**WARNING**

Crankcase pressure can blow hot engine oil out the fill opening, causing severe burns. Always stop the gen-set before removing oil dipstick or oil fill cap.

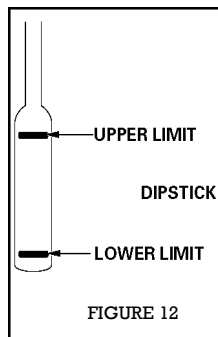

**NOTE:** A typical oil dip stick is shown in figure 12, where as proper oil level should be between “Upper Limit” and “Lower Limit” marks. When oil level reaches “Lower Limit” or below, add necessary oil to bring the level up to “Upper Limit” level on dipstick. After oil check or oil refilling, always replace dip stick and oil filler cap. Check engine owners

guide for proper oil use and other possible caution information that may be required for each engine.

Synthetic oils are NOT recommended for stationary standby generators.

2) Check radiator fluid level on generator sets that are liquid cooled. The radiator was factory filled with a 50% mixture of **DE-IONIZED** water and anti-freeze. Fill radiator to full level only if level is low. **DO NOT OVERFILL ABOVE FULL LEVEL AND NEVER USE TAP WATER WHEN REFILLING RADIATOR.** Tap water will cause eventual calcification within radiator cooling fins, coolant passages in engine block, water pump, engine heaters, etc., and may cause complete engine failure.

**AUTOMATIC TRANSFER SWITCH (ATS)**



The ATS is not of normal products. It is offered as a buyer convenience providing a complete standby power plant product. Eaton and ASCO brands with full UL-1009 Certification are available for Buyer selection.

**NOTE:** It is important for Buyer to know, that all ATS operating methods, parts supplied, operational services, warranties, etc. are the responsibilities of chosen ATS supplier. However, dealer responsibilities are to ensure all such requirements are carried out, by the selected ATS vendor.

A) When all connections, adjustments, and tests are completed, and the automatic transfer switch is installed and wired, the standby generator system is ready to be placed on standby duty. When testing the packaged standby set, using the furnished Automatic Transfer Switch (ATS), refer to included wiring diagrams & ATS owners manual. For an ATS system furnished by others, follow instructions and wiring diagrams furnished with the separate ATS system.

B) **EXERCISER:** Each automatic transfer switch has an exerciser circuit that automatically starts and runs gen-set for a predetermined time, before it shuts down. This "Trial Run" feature is to ensure that system is working and ready to use, when you need it, the most. The automatic engine exerciser must be set for the automatic time to come on, run for a pre-set time, then automatically shut itself down. The installer must set the initial exercising time, depending on the needs of owner. Review the ATS manual for exercising operation.

**IT IS IMPORTANT TO KNOW, THAT WHEN EXERCISING THE SELECTION OF NOT TRANSFERRING THE LOAD TO THE GENERATOR SET, IS THE MOST DESIRABLE METHOD.**

	<b>CAUTION</b>	
<b>THE ELECTRIC LOAD TO BE APPLIED TO GENERATOR SET MUST NEVER BE MORE THAT GENERATOR RATINGS. THE GENERATOR IS RATED IN WATTS. CALCULATE THE ELECTRICAL LOAD TO BE APPLIED TO GENERATOR IN WATTS. NEVER EXCEED 75% OF GENERATOR RATING IN ACTUAL</b>		

It is possible that a different auto transfer switch may be used, rather than the furnished automatic transfer switch (ATS). In this case, any different style or brand, 2-wire ATS will work with generator circuitry. Consult the owners guide and its wiring diagrams, or vendor department for any different ATS system and its method of operation.

D) Simulate a utility power failure by turning off disconnect switch, installed between utility power and auto transfer switch. The auto transfer switch will activate. The "Engine Running" LED (located on control panel) will flash repeatedly for up to 10 seconds (normal time delay to start) until engine begins to start and run. (This may be set to 0 seconds

depending on the specific setup at this location.) The auto transfer switch will switch the connected load from utility to emergency generator power.



Note that engine generator set must start under an immediately applied load. In most cases, the gen-set is strong enough to perform under this demanding scenario. However, if the load is 75% or more inductive (large motors, UPS systems, large air conditioners), it may be necessary to install a time delay device, allowing gen-set to get up and running (approx. 10 seconds), then allow load to be applied.

E) Return the disconnect switch to on position, allowing utility power, to no longer be interrupted. The auto transfer switch will sense this and switch the connected load from emergency generator power, back to utility power. The engine will continue to run for 2 minutes and will allow engine and generator to normally cool down, without connected load.

**OPTIONAL:** The sensing device may not always be 2-wire automatic transfer switch. Many auto start/stop, 2-wire sensing devices such as pressure switch, float switch, temperature switch, may control the start/stop functions of Sentry gen-sets, under special custom applications. However, the operating procedures, as described above, are always the same.

## GENERAL SERVICE TIPS

	<b>CAUTION</b>	
-------------------------------------------------------------------------------------	----------------	---------------------------------------------------------------------------------------

	<p>If the ATS switch is left in the "STANDBY" position at any time, the generator system is being serviced or repaired, the engine may crank and start without warning. Such automatic starting may happen when utility voltage dips below a preset voltage level or during a normal exercise period. To prevent possible injury that may be caused, always set the controller state to the "OFF" position and remove the 20 amp cartridge fuse, while working on or around the generator set, or accompanying automatic transfer switch.</p>	
-------------------------------------------------------------------------------------	-----------------------------------------------------------------------------------------------------------------------------------------------------------------------------------------------------------------------------------------------------------------------------------------------------------------------------------------------------------------------------------------------------------------------------------------------------------------------------------------------------------------------------------------------	-------------------------------------------------------------------------------------

**AIR FILTER:** remove air filter cover and existing air filter element and foam element. Reassemble air filter with new air filter elements in place. Do not oil the filter elements.

**OIL FILTER:** remove oil filter by turning it counterclockwise, using an oil filter wrench. Clean the gasket sealing surface of oil filter holder. Apply a light coat of clean oil to the rubber seal of the new oil filter. Dispose of old filter in an environmentally safe manner. **NOTE:** Best time to replace oil filter is during time of oil change, when oil is drained from engine.

**OIL DRAIN:** Remove oil drain hose from the holding clip. Remove the end cap from end of oil drain hose, and let oil drain into a separate container. Remove dipstick and oil fill cap to facilitate complete draining process. When oil is drained, replace dip stick, oil fill cap, oil hose drain cap and place hose in holding clip.

**OIL FILL:** Replace oil with premium grade API SJ/10W-30 oil when ambient temperature is above 32° F (0° C). When temperature is below 32° F, use a synthetic premium grade, API SJ/CF5W-30W. This synthetic oil facilitates cold weather starting. Oil level should reach “upper limit” level on oil dipstick. **CAUTION:** Too much oil can cause oil foaming, high oil consumption (white smoke emitting from exhaust) or high operating temperature. Also, too little oil (oil level to, or below “lower limit” on oil dipstick) can cause severe engine damage, and premature shut-down.

For best starting results, oil should be scheduled to change, using synthetic oil, just before winter season, in those cold climate areas. After oil is changed, replace dipstick and oil fill cap.

**COOLING SYSTEM:** Engines are liquid cooled with a radiator. Inspect the debris guard on engine air intake to insure no obstructions have accumulated. Inspect radiator to insure no debris accumulation has occurred. Some generator models have bug/rodent screens. Inspect and clean off any aluminum screens that may collect debris.

**EXHAUST SYSTEM:** Engine end of generator set, will be the hot exhaust discharge. Keep any combustibles (building materials, fuels, chemicals, flammables, etc.) away from this exhaust area. Periodically inspect exhaust system components (flexible pipes, mufflers, clamps, etc.) for leaks, cracks, or corrosion. Your muffler maybe equipped with a spark arrestor screen, which prevents exhaust sparks from exiting the exhaust system. This screen must be checked and cleaned, every 50-75 hours of engine operation. **NOTE:** Check run time meter for periods of maintenance.

**CORROSION:** Depending on the area of generator installation, will depend on the amount of attention given to cleanliness. Heavy concentration of salt water exposure will require frequent washings and a final waxing of housing exterior. Salt water corrosion may enter the interior of generator housing, which must be removed by special detergents. Every 3 months, spray the engine governor linkage and other engine moving parts, and engine, generator, base exterior with a light coverage of WD-40 to prevent corrosion build-up, on these parts. Only professional generator repair person should clean and/or spray oil inside the generator housing.



#### **BATTERY INSPECTION SHOULD INCLUDE:**

- Inspect battery posts and cables for corrosion build-up. Clean and tighten as required.
- Have the state of charge and over all condition checked. A fully charged battery should test at 12.5-13.0 volts D.C.
- See battery section on pages 24-25 for further information



After each maintenance repair procedure is complete, remember to replace 20 amp controller fuse, and set controller switch to “STANDBY” position.

#### **OTHER DIESEL GEN-SET CONSIDERATIONS**

**NAFPA-110, LEVEL-1** Requires a thermostatically controlled engine coolant heater to be installed on emergency standby gen-sets. These engine jacket water heaters shall maintain coolant at minimum 90° F (32° C). These engine heaters will help engine starting and starting under load ability.

A battery wrap-around heating blanket should be used to keep starting battery at minimum 50° F (10° C). Battery heaters and engine coolant heaters are automatically disconnected from commercial power, upon standby gen-set start-up.

A 50/50 anti-freeze and di-ionized water solution is recommended for all engines.

The diesel fuel system should provide clean fuel to the generator. Normally, complete gen-set is mounted on top of a double-wall, leak-proof fuel tank with UL-142, plus NFPA-30, 37, and 110 Certification. All plumbing, electrical connections, or safety shut down systems are installed and fuel tank is ready to receive fuel. Occasionally, on large KW systems, the fuel tank is shipped separate from gen-set. Bulk diesel fuel is stored in these large tanks, and is transferred to smaller fuel tanks called “Day Tanks”, which would be located close to generator set.

Check with local authorities to determine if quantity of fuel is limited. If not, NEC and NFPA regulations require that enough fuel is present to run gen-set for minimum two (2) hours, depending on type of facility that requires this emergency power plant. A general guide is to have enough fuel at the gen-set, to run at full load for 2-3 hours. Consult NFPA-37 for additional

specifics on fuel information.

### OPTIONAL DIESEL TANK CONSIDERATIONS

- 1) A flexible fuel line must be used at connection point on the diesel engine (option)
- 2) Five (5) gallon spill/fill container.
- 3) A 2" overfill valve.
- 4) Rain slant on tank cover.
- 5) Immersion heater for operation below 50° F (10° C).

### STANDARD FUEL TANK EQUIPMENT

- 1) Emergency venting to UL standards.
- 2) Rupture tank switch.
- 3) Normal vent, 2" NPT with 10" extension.
- 4) Locking fuel cap, 2" NPT with 10" extension.
- 5) Visual, mechanical level gauge.
- 6) Fuel supply and return lines, 1/2" diameter.
- 7) Low fuel level switch at 50% setting.

8) Double wall heavy duty, 7 gauge steel, "Leak-Proof" construction.

9) Fuel drain with 1/2" NPT plug.

10) Powder coat finish with oil fog interior.

### AREAS REQUIRING SPECIAL DIESEL TANKS

Many states and Regions have specific requirements, for fuel tanks. During tank installation planning, check with local building authorities, local Fire Chief, or other regional authorities. Known areas requesting special diesel tank equipment are: The States of Florida, Michigan, and Washington, plus areas of New York City, Chicago, and Los Angeles.

### DAY TANKS

All gen-set diesel fuel tanks are designed to fit underneath generator set. Special precautions are required to lift these two parts, now considered one assembly, and at much heavier total weight.

If fuel tank is shipped loose from generator set, for purpose of mounting tank remotely from generator, a separate diesel fuel "Day Tank" may be required. There are small 5-10 gallon tanks to allow fuel to immediately reach engine, rather than having engine crank at longer intervals, to get fuel finally to reach engine.

### DIESEL FUEL CONSUMPTION BY MODEL AT FULL LOAD

MODEL NO.	GAL / HR	L / HR	MODEL NO.	GAL / HR	L / HR	MODEL NO.	GAL / HR	L / HR
30-JD	2.8	10.6	250-MT	17.8	67.4	250-CV	18.7	70.7
60-JD	5.0	18.9	280-MT	19.5	73.8	300-CV	21.8	82.7
80-JD	6.6	25.0	300-MT	20.4	77.2	350-CV	25.5	96.5
100-JD	7.9	30.0	350-MT	26.1	98.8	400-CV	27.9	105.6
125-JD	9.3	35.1	400-MT	28.0	105.9	500-CV	36.8	139.3
155-JD	12.1	45.8	450-MT	29.6	109.7	550-CV	39.9	151.0
210-JD	15.5	58.7	500-MT	33.1	125.3	600-CV	40.8	154.4
			550-MT	37.1	140.4			
			600-MT	40.0	151.4			



## TERMINAL CONNECTOR TORQUE

Use the torque values shown for terminal connectors. Refer to UL-486A, UL-486B, and UL-486E for information on terminal connectors for aluminum and/or copper conductors. Comply with applicable national and local codes when installing a wiring system.

**NOTE:** If a connector has a clamp screw such as a slotted, hexagonal head screw with more than one means of tightening, test the connector using both applicable torque values.

## TIGHTENING TORQUE FOR PRESSURE WIRE CONNECTORS WITH INTERNAL-DRIVE SOCKET-HEAD SCREWS

SOCKET SIZE ACROSS FLATS, mm (in.)		TIGHTENING TORQUE, Nm (in. lb.)	
3.2	(1/8)	5.1	(45)
4.0	(5/32)	11.4	(100)
4.8	(3/16)	13.8	(120)
5.6	(7/32)	17.0	(150)
6.4	(1/4)	22.6	(200)
7.9	(5/16)	31.1	(275)
9.5	(3/8)	42.4	(375)
12.7	(1/2)	56.5	(500)
14.3	(9/16)	67.8	(600)

NOTE: For values of slot width or length not corresponding to those specified, select the largest torque value associated with the conductor size. Slot width is the normal design value. Slot length is to be measured at the bottom of the slot.

## TIGHTENING TORQUE FOR SCREW-TYPE PRESSURE WIRE CONNECTORS

WIRE SIZE FOR UNIT CONNECTION	TIGHTENING TORQUE, Nm (in. lb)			
	SLOT HEAD 4.7 mm (NO. 10) OR LARGER *		HEXAGONAL HEAD-EXTERNAL DRIVE SOCKET WRENCH	
	SLOT WIDTH > 1.2 mm (0.047 in.) SLOT LENGTH > 6.4 mm (0.25 in.)	SLOT WIDTH > 1.2 mm (0.047 in.) SLOT LENGTH > 6.4 mm (0.25 in.)	SPLIT-BOLT CONNECTORS	OTHER CONNECTIONS
18-10 (0.82-5.3)	2.3 (20)	4.0 (35)	9.0 (80)	8.5 (75)
8 (8.4)	2.8 (25)	4.5 (40)	9.0 (80)	8.5 (75)
6-4 (13.3-21.2)	4.0 (35)	5.1 (45)	18.6 (165)	12.4 (110)
3 (26.7)	4.0 (35)	5.6 (50)	31.1 (275)	16.9 (150)
2 (33.6)	4.5 (40)	5.6 (50)	31.1 (275)	16.9 (150)
1 (42.4)	-	5.6 (50)	31.1 (275)	16.9 (150)
1/0-2/0 (53.5-67.4)	-	5.6 (50)	43.5 (385)	20.3 (180)
3/0-4/0 (85.0-107.2)	-	5.6 (50)	56.5 (500)	28.2 (250)
250-350 (127-177)	-	5.6 (50)	73.4 (650)	36.7 (325)
400 (203)	-	5.6 (50)	93.2 (825)	36.7 (325)
500 (253)	-	5.6 (50)	93.2 (825)	42.4 (375)
600-750 (304-380)	-	5.6 (50)	113.0 (1000)	42.4 (375)
800-1000 (406-508)	-	5.6 (50)	124.3 (1100)	56.5 (500)
1250-2000 (635-1016)	-	-	124.3 (1100)	67.8 (600)

\* For values of slot width or length not corresponding to those specified, select the largest torque value associated with the conductor size. Slot width is the normal design value. Slot length is to be measured at the bottom of the slot.

NOTE: If a connector has a clamp screw such as a slotted, hexagonal head screw with more than one means of tightening, test the connector using both applicable torque values.

# FORMULAS THAT MAY BE OF USE

<b>TEMPERATURE</b>	$^{\circ}\text{C} = (^{\circ}\text{F} - 32) \times 0.55555$	$^{\circ}\text{F} = (^{\circ}\text{C} \times 1.8) + 32$
<b>VELOCITY</b>	$\text{ft}/\text{sec} \times 0.3048 = \text{m}/\text{sec}$ $\text{miles}/\text{hr} \times 1.6093 = \text{km}/\text{hr}$ $\text{miles}/\text{hr} \times 0.44704 = \text{m}/\text{sec}$	$\text{m}/\text{sec} \times 3.2808 = \text{ft}/\text{sec}$ $\text{km}/\text{hr} \times 0.6214 = \text{miles}/\text{hr}$ $\text{m}/\text{sec} \times 3.2808 = \text{ft}/\text{sec}$
<b>VOLUME</b>	$\text{inches}^3 \times 16.388 = \text{mm}^3$ $\text{feet}^3 \times 0.0283 = \text{m}^3$ $\text{gallons} \times 3.785 = \text{liter}$ $\text{gallons} \times 0.13337 = \text{ft}^3$	$\text{cc}^3 \times 0.06102 = \text{inches}^3$ $\text{m}^3 \times 35.315 = \text{feet}^3$ $\text{liter} \times 0.2642 = \text{gallon}$
<b>PRESSURE</b>	$\text{pounds}/\text{ft}^2 \times 0.006944 = \text{pounds}/\text{in}^2$ $\text{psi} \times 6.8948 = \text{kPa}$ $\text{psi} = 0.4912 \text{ inches Hg}$	$\text{pounds}/\text{in}^2 \times 144 = \text{pounds}/\text{ft}^2$ $\text{kPa} \times 0.1450 = \text{psi}$ $\text{kPa} = 0.1333 \times \text{inches Hg}$
<b>MISCELLANEOUS</b>	$\text{Watt} \times 0.00134 = \text{hp}$ $\text{BTU}/\text{hr} \times 0.293 = \text{Watts}$ $\text{BTU}/\text{hr} \times 0.0003929 = \text{hp}$	$\text{Watts} \times 3.4122 = \text{BTU}/\text{hr}$ $\text{hp} \times 2545.177 = \text{BTU}/\text{hr}$
<b>AREA</b>	$\text{inches}^2 \times 6.451 = \text{cm}^2$ $\text{feet}^2 \times 0.0929 = \text{m}^2$	$\text{cm}^2 \times 0.394 = \text{inches}^2$ $\text{m}^2 \times 10.764 = \text{feet}^2$
<b>TORQUE</b>	$\text{oz-in} \times 0.007062 = \text{Nm}$ $\text{lb-in} \times 0.11296 = \text{Nm}$ $\text{lb-ft} \times 1.356 = \text{Nm}$	$\text{Nm} \times 141.6029 = \text{oz-in}$ $\text{Nm} \times 8.8495 = \text{lb-in}$ $\text{Nm} \times 0.7376 = \text{lb-ft}$

## SINGLE PHASE ELECTRIC

Single Phase Power Factor is typically 1.0  
 1 kW = 1 kilo Watt = 1,000 Watts

Watts = Volts x Amps x Power Factor

$$\text{Amps} = \frac{\text{Watts}}{\text{Volts} \times \text{Power Factor}}$$

## THREE PHASE ELECTRIC

Three Phase Power Factor is typically 0.8  
 1 kW = 1 kilo Watt = 1,000 Watts

Watts = (Volts x Amps x Power Factor) x 1.732

$$\text{Amps} = \frac{\text{Watts}}{\text{Volts} \times \text{Power Factor} \times 1.732}$$

# **GeneratorJoe<sup>®</sup>**

**4723 Muirfield Court  
Santa Rosa, CA 95405**

**Phone: 707 542-2224**

**Fax: 707 542-2227**

**Email: [sales@generatorjoe.Net](mailto:sales@generatorjoe.Net)**

**Web: [www.generatorjoe.NET](http://www.generatorjoe.NET)**

---

## **AUTOMATIC POWER SYSTEMS**